

# LED..O..M Series Diffused On-Axis Lights



## Datasheet

Uniform lighting for machine vision applications



- Diffused on-axis illumination provides uniform lighting for specular surfaces
- Five light colors
- Two sizes available
- Continuous or strobed operation selectable via sensor software
- Glass dust-covered models available (model numbers ending in -D)
- Bracket options available

## Models

Without Dust Cover	With Dust Cover <sup>1</sup>	Color	Aperture Size	Cable <sup>2</sup>	Connections	Ambient Light Filter Kit
LEDRO50M	LEDRO50M-D	Visible Red (630 nm)	50 mm	0.6 m (2 ft) attached pigtail	8 mm male Pico-style (for direct connection to PresencePLUS P4 sensor)	FLTR
LEDIO50M	LEDIO50M-D	Infrared (880 nm)				FLTI
LEDBO50M	LEDBO50M-D	Blue (470 nm)				FLTB
LEDWO50M	LEDWO50M-D	White (5500 K)				—
LEDGO50M	LEDGO50M-D	Green (530 nm)				FLTG
LEDRO100M	LEDRO100M-D	Visible Red (630 nm)	100 mm			FLTR
LEDIO100M	LEDIO100M-D	Infrared (880 nm)				FLTI
LEDBO100M	LEDBO100M-D	Blue (470 nm)				FLTB
LEDWO100M	LEDWO100M-D	White (5500 K)				—
LEDGO100M	LEDGO100M-D	Green (530 nm)				FLTG

## Features

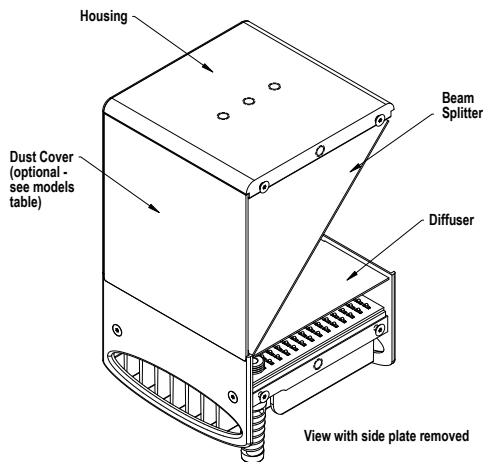

Figure 1. View With Side Plate Removed

<sup>1</sup> Optical glass anti-reflective coating, both sides.

<sup>2</sup> Extension cables with flying leads are available for connecting to models other than PresencePLUS P4.



## Wiring

On-Axis Light Wire	PresencePLUS Pro Controller Terminal Block	External Power Supply (Strobed)	External Power Supply (Continuous)
Brown	Pin 1, +V (24 V dc $\pm$ 10%)	+V	+V
Blue	Pin 2, -V (dc common)	-V	-V
Black	Pin 4 (strobe)	+5 V dc to 24 V dc OFF	-V
		-V ON	

## Specifications

### Light Source

Visible red LED, 630 nm ; Infrared, 880 nm ; Visible blue, 470 nm; White, 5500 K, or Green

### Supply Voltage and Current

24 V dc  $\pm$  10% 500 mA maximum, 125 mA maximum for 50 mm models.  
Direct connect to PresencePLUS P4 sensor operating at 24 V dc only  
Use only with a suitable Class 2 power supply (UL) or SELV power supply (CE)

### Construction

Housing: aluminum with black anodizing  
Beam Splitter: optical glass with optical coatings on both sides  
Diffuser: high-precision cast acrylic  
Dust Cover: optical glass with broadband anti-reflective coating (425 nm to 675 nm) (some models)

### Useful Life

When operated within specifications, output will decrease less than 20% after 10,000 hours and less than 30% after 20,000 hours (based on continuous operation).



**Note:** Actual useful life of strobed lights depends on duty cycle.

### Operating Conditions

**Temperature:** 0 °C to +50 °C (+32 °F to +122 °F)

**Humidity:** 90% at +50 °C maximum relative humidity (non-condensing)

### Cleaning Instructions

Handle the sensor with care during installation and operation. Sensor windows soiled by fingerprints, dust, water, oil, etc. may create stray light that may degrade the peak performance of the sensor. Blow the window clear using filtered, compressed air, then clean as necessary using a lens cloth and lens cleaner or window cleaner. Do not use any other chemicals for cleaning.

### Installation

Before installing an on-axis light, it is recommended that the listed ambient light filter be installed behind the camera lens. The filter improves image quality by reducing unwanted ambient light.

- 100 mm models: 50 x 50 mm suggested field of view and 25 mm minimum suggested stand off
- 50 mm models: 25 x 25 mm suggested field of view and 25 mm minimum suggested stand off

### Certification



## Dimensions

All measurements are listed in millimeters [inches], unless noted otherwise.

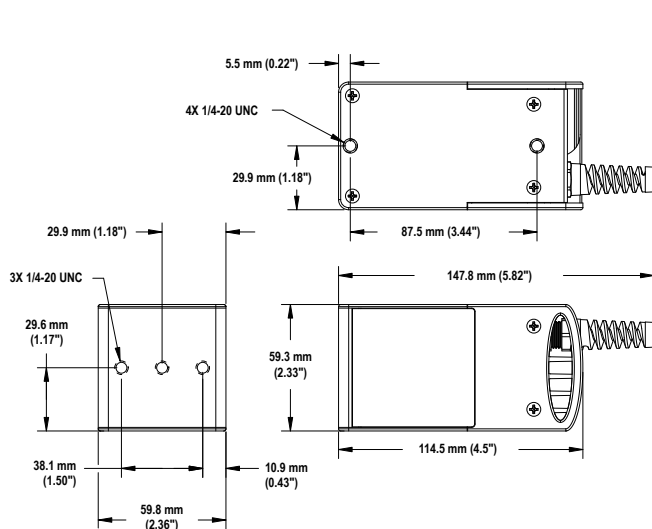

Figure 2. 55 mm Models

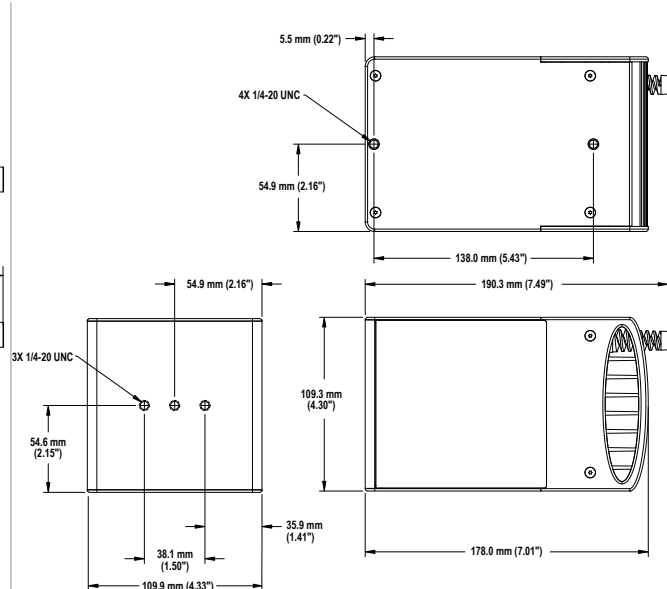
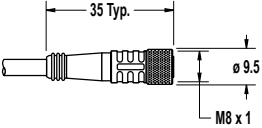



Figure 3. 100 mm Models

## Accessories

### Cordsets

3-Pin Threaded M8/Pico-Style Cordsets				
Model	Length	Style	Dimensions	Pinout (Female)
PKG3M-2	2 m (6.56 ft)	Straight		 <p>1 = Brown 3 = Blue 4 = Black</p>
PKG3M-5	5 m (16.40 ft)			
PKG3M-7	7 m (22.97 ft)			
PKG3M-9	9 m (29.53 ft)			
PKG3M-10	10 m (32.81 ft)			

### Mounting Brackets

#### SMBP4OAL100

- For use with right-angle or in-line P4 sensors and 100 mm on-axis light
- Centers lens on light opening
- Black zinc-plated steel
- (4) M5 and (4) ¼-20 socket drive, button-head screws included

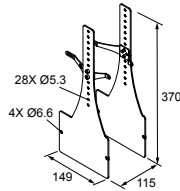

#### SMBPPOAL100

- For use with Pro sensors and 100 mm on-axis light
- Centers lens on light opening
- Black zinc-plated steel
- (4) M5 and (4) ¼-20 socket drive, button-head screws included

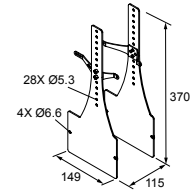

#### SMBP4OAL50

- For use with right-angle or in-line P4 sensors and 50 mm on-axis light
- Centers lens on light opening
- Black anodized aluminum and zinc-plated steel
- (4) M3 flat head torx, (4) M5 and (4) ¼-20 socket drive, button-head screws included

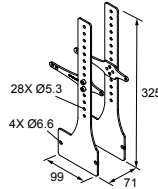

#### SMBPPOAL50

- For use with Pro sensors and 50 mm on-axis light
- Centers lens on light opening
- Black zinc-plated steel
- (4) M5 and (4) ¼-20 socket drive, button-head screws included

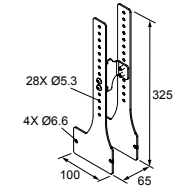

## Banner Engineering Corp. Limited Warranty

Banner Engineering Corp. warrants its products to be free from defects in material and workmanship for one year following the date of shipment. Banner Engineering Corp. will repair or replace, free of charge, any product of its manufacture which, at the time it is returned to the factory, is found to have been defective during the warranty period. This warranty does not cover damage or liability for misuse, abuse, or the improper application or installation of the Banner product.

**THIS LIMITED WARRANTY IS EXCLUSIVE AND IN LIEU OF ALL OTHER WARRANTIES WHETHER EXPRESS OR IMPLIED (INCLUDING, WITHOUT LIMITATION, ANY WARRANTY OF MERCHANTABILITY OR FITNESS FOR A PARTICULAR PURPOSE), AND WHETHER ARISING UNDER COURSE OF PERFORMANCE, COURSE OF DEALING OR TRADE USAGE.**

This Warranty is exclusive and limited to repair or, at the discretion of Banner Engineering Corp., replacement. **IN NO EVENT SHALL BANNER ENGINEERING CORP. BE LIABLE TO BUYER OR ANY OTHER PERSON OR ENTITY FOR ANY EXTRA COSTS, EXPENSES, LOSSES, LOSS OF PROFITS, OR ANY INCIDENTAL, CONSEQUENTIAL OR SPECIAL DAMAGES RESULTING FROM ANY PRODUCT DEFECT OR FROM THE USE OR INABILITY TO USE THE PRODUCT, WHETHER ARISING IN CONTRACT OR WARRANTY, STATUTE, TORT, STRICT LIABILITY, NEGLIGENCE, OR OTHERWISE.**

Banner Engineering Corp. reserves the right to change, modify or improve the design of the product without assuming any obligations or liabilities relating to any product previously manufactured by Banner Engineering Corp. Any misuse, abuse, or improper application or installation of this product or use of the product for personal protection applications when the product is identified as not intended for such purposes will void the product warranty. Any modifications to this product without prior express approval by Banner Engineering Corp will void the product warranties. All specifications published in this document are subject to change; Banner reserves the right to modify product specifications or update documentation at any time. Specifications and product information in English supersede that which is provided in any other language. For the most recent version of any documentation, refer to: [www.bannerengineering.com](http://www.bannerengineering.com).

For patent information, see [www.bannerengineering.com/patents](http://www.bannerengineering.com/patents).