

## Datasheet

Self-contained Class 1 laser distance sensor with analog and discrete outputs.

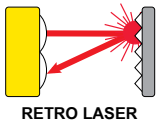

- Extremely long range: 50 m when using the BRT-TVHG-8x10P high-grade target
- Banner's unique scalable analog output automatically distributes the output signal across the width of the programmed sensing window
- Analog and discrete (switched) outputs in each sensor, with independent window limits <sup>1</sup>
- Discrete output can be used for precise background suppression
- Choose NPN or PNP discrete output, plus 0 to 10 V dc or 4 to 20 mA sourcing analog output
- Fast, easy-to-use integrated push button TEACH-mode programming; no potentiometer adjustments
- Remote TEACH-function for security and convenience
- Output response is programmable for three speeds
- Choose 2 m or 9 m unterminated cable, or 8-pin Euro-style swivel quick-disconnect connector
- Rugged construction withstands demanding sensing environments; IEC IP67, NEMA 6



### WARNING: Not To Be Used for Personnel Protection

Never use this device as a sensing device for personnel protection. Doing so could lead to serious injury or death. This device does not include the self-checking redundant circuitry necessary to allow its use in personnel safety applications. A sensor failure or malfunction can cause either an energized or de-energized sensor output condition.



### CAUTION: Do Not Disassemble for Repair

This device contains no user-serviceable components. Do not attempt to disassemble for repair. Use of controls or adjustments or performance of procedures other than those specified herein may result in hazardous radiation exposure. A defective unit must be returned to the manufacturer.

## Models

| Models   | Sensing Distance   | Cable <sup>2</sup>  | Discrete Output | Analog Output                      |                                |
|----------|--|---------------------|-----------------|------------------------------------|--------------------------------|
| LT3PULV  | 0.5 m to 50 m (19.7 in to 164 in) for reflector BRT-TVHG-8X10P For more information, see <a href="#">Specifications</a> on page 6. | 2 m (6.5 ft) 8-wire | PNP (Sourcing)  | Analog Voltage (0 V dc to 10 V dc) |                                |
| LT3PULVQ |  | 8-pin Euro-style QD |                 |                                    |                                |
| LT3NULV  |  | 2 m (6.5 ft) 8-wire | NPN (Sinking)   |                                    |                                |
| LT3NULVQ |  | 8-pin Euro-style QD |                 |                                    |                                |
| LT3PILV  |  | 2 m (6.5 ft) 8-wire | PNP (Sourcing)  |                                    | Analog Current (4 mA to 20 mA) |
| LT3PILVQ |  | 8-pin Euro-style QD |                 |                                    |                                |
| LT3NILV  |  | 2 m (6.5 ft) 8-wire | NPN (Sinking)   |                                    |                                |
| LT3NILVQ |  | 8-pin Euro-style QD |                 |                                    |                                |

## Theory of Operation

A short electrical pulse drives a semiconductor laser diode to emit a pulse of light. The emitted light is collimated through a lens, which produces a very narrow laser beam. The laser beam bounces off the target, scattering some of its light through the sensor's receiving lens to a photodiode, which creates an electrical pulse. The time interval between the two electrical pulses (transmitting and receiving the beam) is used to calculate the distance to the target, using the speed of light as a constant.

Multiple pulses are evaluated by the sensor's microprocessor, which calculates the appropriate output value. The analog output provides a variable signal (4 mA to 20 mA or 0 V dc to 10 V dc, depending on model) that is proportional to the target's position within the user-programmed analog window limits. The discrete (switched) output energizes whenever the target is located between the user-programmed discrete window limits. Window limits for the analog and discrete outputs may be the same, or they may be programmed independently.

<sup>1</sup> See Banner website for information on diffuse and dual-discrete models at: [www.bannerengineering.com](http://www.bannerengineering.com)

<sup>2</sup> To order the 9 m cable models, add the suffix W/30 to the model number of a cabled sensor. For example, LT3PULV W/30. A model with a QD-connector requires a mating cable.



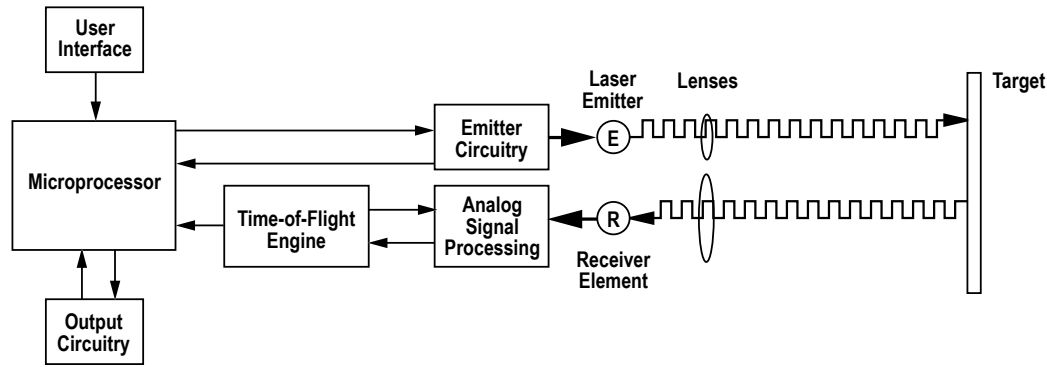

Figure 1. Theory of Operation

## Configuration Instructions

### Sensor Power-Up and Laser-Enable

Power up the sensor for 30 minutes to allow the sensor's internal temperature to stabilize before operating or attempting to program the sensor. If the sensor is used in applications where the temperature is several degrees higher or lower than the ambient temperature, allow the sensor to stabilize in that condition before programming the window limits. The range decreases when the sensor warms up.

The Laser-Enable feature allows the sensor to be continually powered and enabled only when being used. This eliminates the need for the extended warm-up period between uses.

The sensor's red Signal LED indicates the condition of the received signal from the object being measured. When programming the window limits, this LED must be on (not flashing) for the sensor to accept the setting. To ensure the received signal will not be marginal during operation, move the target object 300 mm beyond the furthest desired switch point during setup and verify the signal LED is still on.

### Indicators

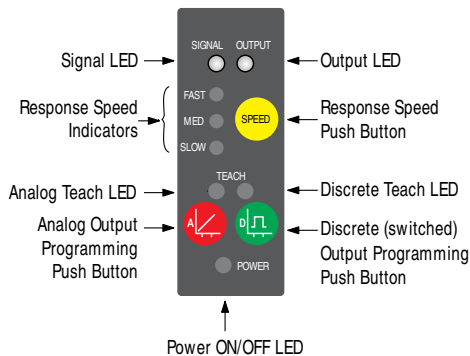

**Power ON/ OFF LED** (green)—Indicates the operating status of the sensor.

| Power ON/ OFF LED Status | Indicates  |
|--------------------------|--|
| Off                      | Power is off   |
| Flashing at 2 Hz         | Discrete output is overloaded (Run mode)                               |
| Flashing at 1 Hz         | Power is on; laser is disabled   |
| On                       | Power is on; the sensor is operating normally and the laser is enabled |

**Power-Up/ Laser-Enable Indicators**—When powering up the sensor all LEDs turn on for one second. Allow a 0.6-second delay for Laser-Enable.

| Selected Response Speed | Laser-Enable Time | Laser-Disable Time |
|-------------------------|-------------------|--------------------|
| Slow                    | 150 ms            | 50 ms              |
| Medium                  | 60 ms             |                    |
| Fast                    | 51 ms             |                    |

**Output LED** (amber)—Lights when a target is sensed within the programmed discrete window.

**Response Speed** (amber)—Indicates the response speed setting.

**Signal LED (red)**—Indicates the strength and condition of the sensor’s incoming signal.

| Signal LED Status | Indicates   |
|-------------------|---|
| On                | Good signal   |
| Off               | No signal is received or the target is beyond the range limitations of the sensor (with some tolerance beyond the recommended minimum and maximum sensing distance) |
| Flashing          | Marginal signal strength (cannot teach limits)  |

## Response Speed

Before setting window limits, use the sensor’s speed button to toggle between the three response speed settings. The selected speed will be indicated by one of the three response speed indicator LEDs.

|        | Discrete Output Response Speed | Analog Output Frequency Response (-3dB)   |
|--------|--------------------------------|---|
| Slow   | 100 ms ON and OFF              | 2.5 Hz (192 ms average/ 1 ms update rate) |
| Medium | 10 ms ON and OFF               | 10 Hz (48 ms average/ 1 ms update rate)   |
| Fast   | 1 ms ON and OFF                | 114 Hz (6 ms average/ 1 ms update rate)   |

## Programming

**Remote Programming**—To program the sensor remotely or to disable the keypad, use the Remote Programming function. Disabling the keypad prevents accidental or unauthorized adjustment of the programming settings. Connect the yellow wire of the sensor to +5 V dc to 24 V dc, with a remote programming switch connected between them.



**Note:** The impedance of the remote teach input is 55 kΩ.

Programming is accomplished by following the sequence of input pulses. The duration of each pulse (corresponding to a push button “click”) and the period between multiple pulses are defined as “T”: 0.04 seconds ≤ T ≤ 0.8 seconds.

**Analog Output Slope**—The L-GAGE LT3 Sensor may be programmed for either a positive or a negative output slope, based on which condition is taught first. If the near limit is taught first, the slope will be positive. If the far limit is taught first, the slope will be negative. Banner’s unique scalable analog output (patent pending) automatically distributes the output signal across the width of the programmed sensing window.

In the event of analog signal loss for longer than 2 seconds, the analog output goes to 0 V dc or 3.6 mA, which may be used to trigger an alarm.

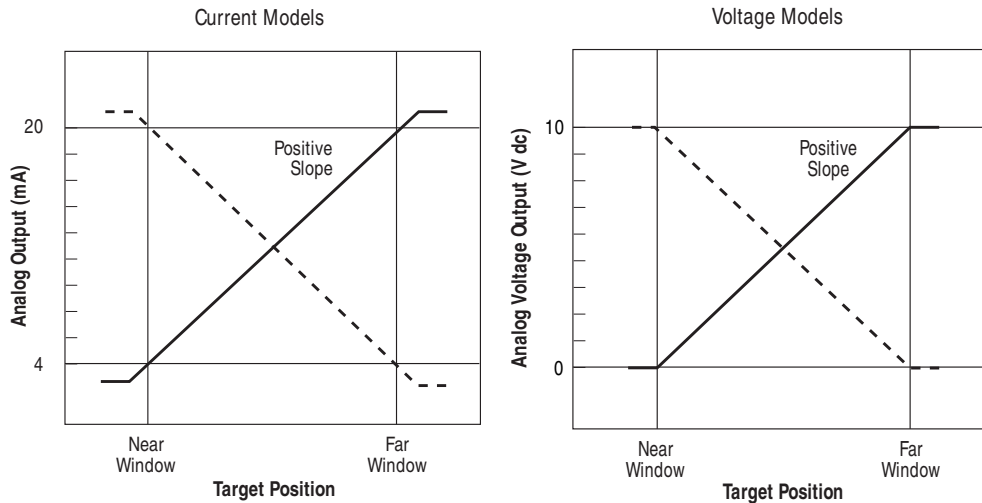

Figure 2. Analog Output as a Function of Target Position



**Note:** The linear analog output tracks slightly past each window limit (from 3.8 mA to 20.5 mA).

## Teaching Limits for Background Suppression

For some applications, ignoring objects beyond a certain distance may be required. To suppress the background, place a target object at the selected distance, and teach the position twice. The sensor’s discrete output will activate when an object is detected between the sensor’s minimum sensing distance and the taught position.



**Note:** The sensor allows for some forgiveness in this procedure. If the two limits are not exactly the same (but less than 20 mm apart), the sensor will put the set point at the “average” of the two limits.

Program either analog output or discrete output first. For the button or the remote wire, a button click or pulse is: 0.04 seconds ≤ T ≤ 0.8 seconds.

## Teaching Independent Limits for Either Output

**Teaching Analog Limits Using the Auto-Zero Feature (Analog Output)**—For some analog applications, a sensing distance switch point centered within a sensing window may be required. The TEACH procedure is simple: teaching the same limit twice causes the sensor to program a window centered on the position taught. This window is 10 m wide (taught position  $\pm 5$  m).

To exit Program mode without saving changes, press and hold the same push button (or hold the remote line high) for longer than 2 seconds (before teaching the second limit). The sensor will revert to the last saved program.

1. Enter programming mode.

| Method              | Action  | Result   |
|---------------------|---|--|
| <b>Push Button</b>  | Push and hold the button for either output for longer than 2 seconds. The sensor will return to RUN mode if first TEACH-condition is not registered within 120 seconds. | The appropriate TEACH-LED turns ON. The sensor is waiting for first limit. |
| <b>Remote Input</b> | No action required.   |  |

2. Teach the first limit.

| Method              | Action   | Result   |
|---------------------|--|--|
| <b>Push Button</b>  | Position the target for the first limit. Click the same button.  | The appropriate TEACH LED turns ON then flashes at 2 Hz. The sensor learns the first limit and waits for the second limit. |
| <b>Remote Input</b> | Position the target for the first limit.<br>For the discrete output, single-pulse the remote line.<br>For the analog output, double-pulse the remote line. |  |

3. Teach the second limit.

| Method              | Action   | Result  |
|---------------------|--|---|
| <b>Push Button</b>  | Position the target for the second limit. Click the same button.           | The TEACH LED goes OFF. The sensor learns the second limit and returns automatically to Run mode. |
| <b>Remote Input</b> | Position the target for the second limit and single-pulse the remote line. |   |

4. Program the second output by repeating steps two and three.

## Teaching Identical Limits to Both Outputs

When teaching limits simultaneously, both the outputs will have identical limits.

To exit Program mode without saving changes, press and hold the same push button (or hold the remote line high) for longer than 2 seconds (before teaching the second limit). The sensor will revert to the last saved program.

1. Enter programming mode.

| Method              | Action  | Result   |
|---------------------|---|--|
| <b>Push Button</b>  | Push and hold the button for either output for longer than 2 seconds. The sensor will return to RUN mode if the first TEACH condition is not registered within 120 seconds. | The appropriate TEACH LED turns ON.  |
|                     | Briefly click the other output button.  | The appropriate TEACH LED turns ON. The sensor is waiting for the first limit. |
| <b>Remote Input</b> | No action required.   |  |

2. Teach the first limit.

| Method              | Action  | Result   |
|---------------------|---|--|
| <b>Push Button</b>  | Position the target for the first limit. Click either output button.        | Both TEACH LEDs flash at 2 Hz, alternating red and green. The sensor learns the first limit and waits for the second limit.                          |
| <b>Remote Input</b> | Position the target for the first limit, then triple-pulse the remote line. | Both TEACH LEDs turn ON. The sensor learns the first limit and waits for the second limit. Both TEACH LEDs flash at 2 Hz, alternating red and green. |

3. Teach the second limit.

| Method              | Action   | Result  |
|---------------------|--|---|
| <b>Push Button</b>  | Position the target for the second limit. Click either output button.        | Both TEACH LEDs go OFF. The sensor learns the second limit and returns automatically to Run mode. |
| <b>Remote Input</b> | Position the target for the second limit, then single-pulse the remote line. |   |

## Enabling or Disabling the Push Button

In addition to its programming function, the remote line may be used to disable the push buttons for security. Disabling the push buttons prevents undesired tampering with the sensor configuration settings.

1. Connect the sensor's gray wire.
2. Four-pulse the remote line to enable or disable the push button.  
The sensor toggles between enable and disable settings and returns to RUN mode.

## Installation Instructions

### Wiring

**NPN Analog Current**

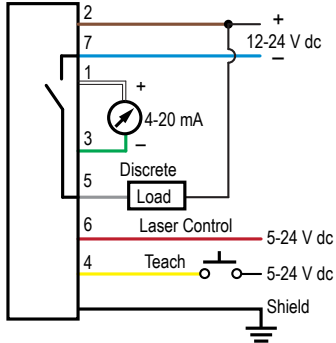

**PNP Analog Current**

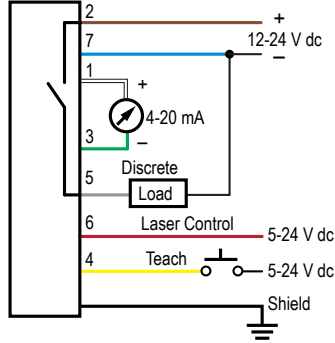

**Key**

1. White
2. Brown
3. Green
4. Yellow
5. Gray
6. Pink
7. Blue

Quick disconnect (QD) wiring diagrams are functionally identical.

**NPN Analog Voltage**

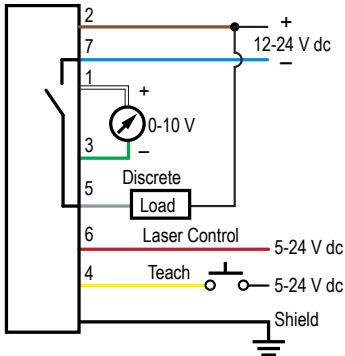

**PNP Analog Voltage**

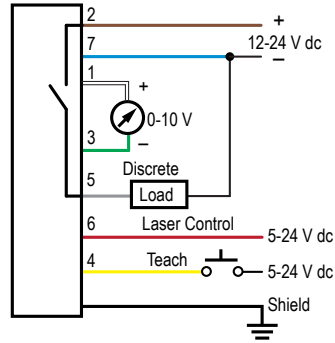

## Specifications

### Sensing Range (Retroreflective Model)

0.5 to 50 m (using BRT-TVHG-8X10P)

### Supply Voltage and Current

12 V dc to 24 V dc (10% maximum ripple)  
108 mA maximum at 24 V dc or [2600/V dc] mA

### Supply Protection Circuitry

Protected against reverse polarity and transient voltages

### Delay at Power-up

1 second; outputs do not conduct during this time

### Sensing Beam

658 nm visible red IEC and CDRH Class 1 laser  
Radiant output power: 0.15 mW maximum  
Typical laser lifetime: 75,000 hours

### Output Protection

Protected against short circuit conditions

### Output Configuration

Discrete (switched): SPST solid-state switch; choose NPN (current sinking) or PNP (current sourcing) models  
Analog output: 0 V dc to 10 V dc or 4 mA to 20 mA

### Output Rating (Discrete)

100 mA maximum  
Off-state leakage current: < 5  $\mu$ A  
Output saturation NPN: < 200 mV at 10 mA and < 600 mV at 100 mA  
Output saturation PNP: < 1.2 V at 10 mA; < 1.6 V at 100 mA

### Output Rating (Analog)

Voltage output: 2.5 k $\Omega$  minimum load impedance  
Current output: 1 k $\Omega$  maximum at 24 V; maximum load resistance =  $[V_{cc}-4.5/0.02 \Omega]$

### Output Response Time (Discrete)

Fast: 1 ms ON and OFF  
Medium: 10 ms ON and OFF  
Slow: 100 ms ON and OFF

### Output Response Time (Analog voltage output (-3 dB))

Fast: 114 Hz (6 ms average/ 1 ms update rate)  
Medium: 10 Hz (48 ms average/ 1 ms update rate)  
Slow: 2.5 Hz (192 ms average/ 1 ms update rate)

### Application Note

Allow 30-minute warm-up before programming or operating

### Factory Default Settings

Response speed: 100 ms discrete, 2.5 Hz analog  
Analog/discrete window limits 0.5 m to 50 m using supplied BRT-TVHG-8X10P target  
Positive analog slope  
Push buttons enabled

### Resolution/Repeatability

See Performance Curves

### Laser Control

Enable: connect red wire to +5 to 24 V dc  
Disable: connect to 0 to +1.8 V dc (or open connection)

### Construction

ABS housing; acrylic window; ABS polycarbonate blend quick disconnect fitting

### Connections

2 m (6.5 ft) or 9 m (30 ft) shielded 7-conductor (with drain) PVC-jacketed attached cable or 8-pin M 12/ Euro-style quick-disconnect

### Linearity

$\pm$  60 mm from 0.5 m to 50 m (0.12% of full scale)  
(Specified at 24 V dc, 22 °C using a BRT-TVHG-8X10P retroreflector)

### Discrete Output Hysteresis (Retroreflective model)

Fast: 20 mm  
Medium: 10 mm  
Slow: 6 mm

### Remote Teach Input

18 k $\Omega$  minimum (65 k $\Omega$  at 5 V dc)

### Temperature Effect

Retroreflective models: < 3 mm / °C

### Minimum Window Size

Retroreflective model: 40 mm

### Environmental Rating

IEC IP67; NEMA 6

### Operating Conditions

0 °C to +50 °C (+32 °F to +122 °F)  
90% at +50 °C maximum relative humidity (non-condensing)

### Certifications

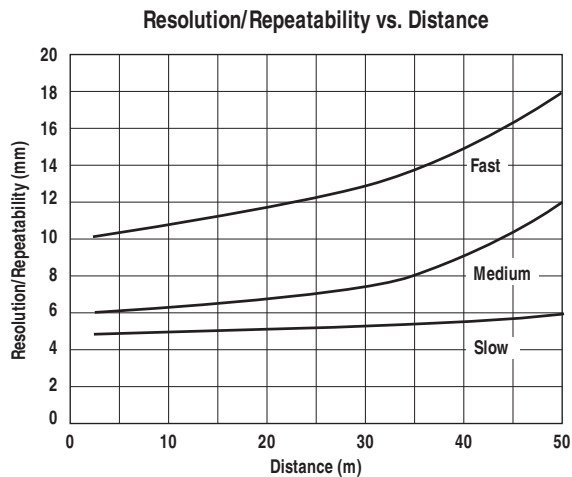

Figure 3. LT3 resolution/repeatability (retroreflective mode)



### Class 1 Lasers

Class 1 lasers are lasers that are safe under reasonably foreseeable conditions of operation, including the use of optical instruments for intrabeam viewing.

Reference IEC 60825-1:2001, Section 8.2.

## Dimensions

### Mounting Hardware:

M4 x 0.7 x 40 socket-head cap screw.  
M4 x 0.7 hex nut with captured, toothed lock washer.  
M3 short-arm hex key.

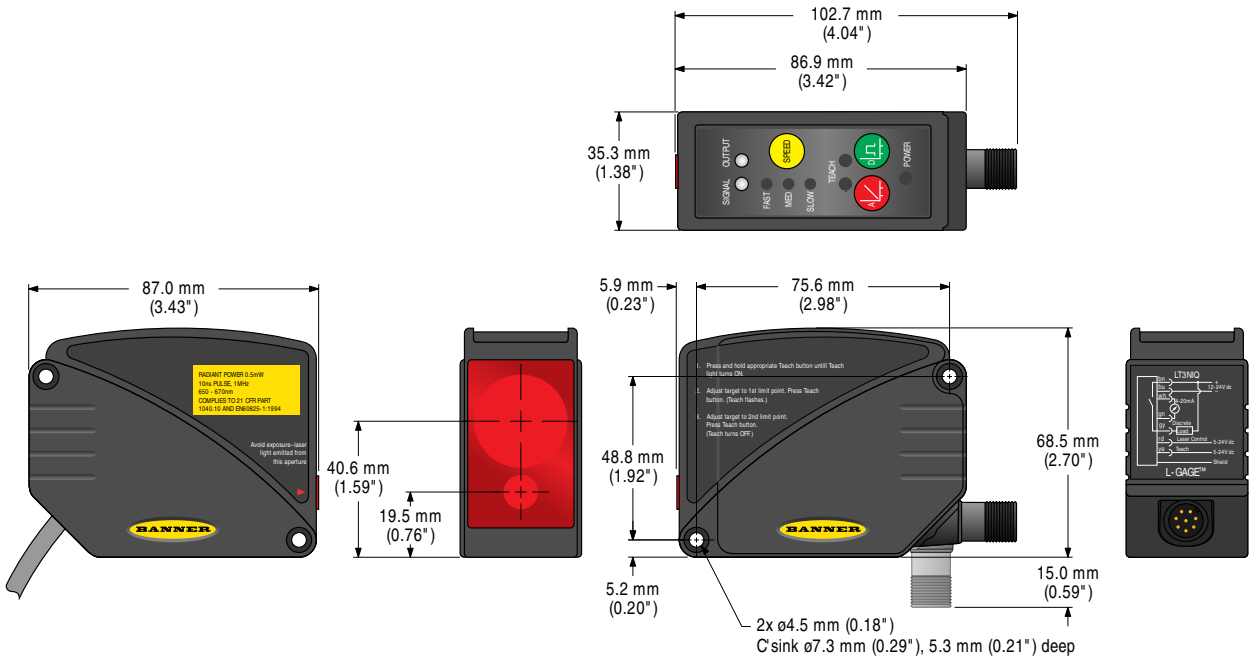

## Accessories

| 8-Pin Threaded M 12/ Euro-Style Cordsets with Shield |                |          |            |  |           |          |           |          |           |          |            |            |
|--|----------------|----------|------------|--|-----------|----------|-----------|----------|-----------|----------|------------|------------|
| Model  | Length         | Style    | Dimensions | Pinout (Female)  |           |          |           |          |           |          |            |            |
| M QDC-806  | 1.83 m (6 ft)  | Straight |            |  |           |          |           |          |           |          |            |            |
| M QDC-815  | 4.57 m (15 ft) |          |            |  |           |          |           |          |           |          |            |            |
| M QDC-830  | 9.14 m (30 ft) |          |            |  |           |          |           |          |           |          |            |            |
|  |                |          |            | <table border="0"> <tr> <td>1 = White</td> <td>5 = Gray</td> </tr> <tr> <td>2 = Brown</td> <td>6 = Pink</td> </tr> <tr> <td>3 = Green</td> <td>7 = Blue</td> </tr> <tr> <td>4 = Yellow</td> <td>8 = Shield</td> </tr> </table> | 1 = White | 5 = Gray | 2 = Brown | 6 = Pink | 3 = Green | 7 = Blue | 4 = Yellow | 8 = Shield |
| 1 = White  | 5 = Gray       |          |            |  |           |          |           |          |           |          |            |            |
| 2 = Brown  | 6 = Pink       |          |            |  |           |          |           |          |           |          |            |            |
| 3 = Green  | 7 = Blue       |          |            |  |           |          |           |          |           |          |            |            |
| 4 = Yellow   | 8 = Shield     |          |            |  |           |          |           |          |           |          |            |            |

## Retroreflectors

| Model          | Reflectivity Factor | Maximum Temperature | Size         |
|----------------|---------------------|---------------------|--------------|
| BRT-TVHG-8X10P | 0.8                 | +60 °C (+140 °F)    | 203 x 254 mm |



**Note:** Retroreflective material has a pressure-sensitive adhesive on it. Surfaces must be clean and dry before applying the adhesive. For best results, use a full-size target and trim it if needed.

