

Q23s are miniature right-angle sensors

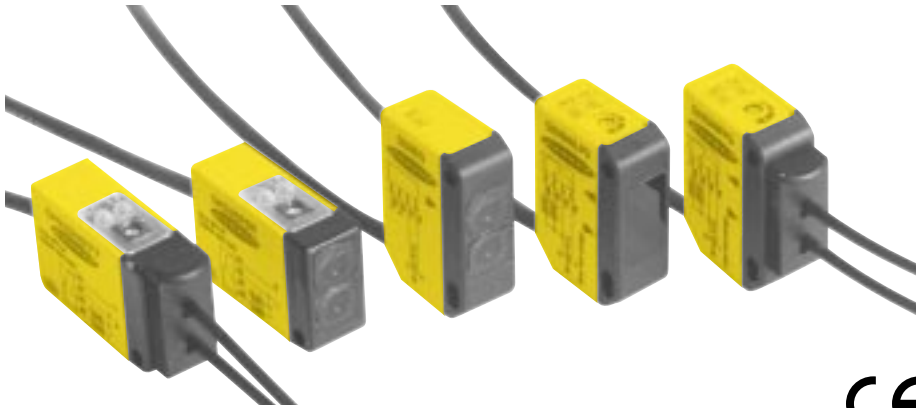

QH23s feature in-line (horizontal) design



## Features

- Totally self-contained; 10 to 30V dc operation
- Powerful visible red sensing beam simplifies setup and alignment
- Sensors include self-diagnostic circuitry; one output may be used as a marginal signal alarm<sup>†</sup>
- Circuitry is completely sealed in ABS housing; rated IP67 and NEMA 6
- Choose NPN (sinking) or PNP (sourcing) models; outputs are short circuit protected and rated for up to 150 milliamp load
- LED indications for Power ON, Output Status (including overload condition), Alignment and Marginal Signal
- Stainless steel right-angle mounting bracket and hardware are included (see page 7 and 8)

## Q23 Sensing Mode Options

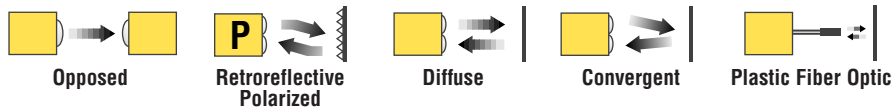

<sup>†</sup> U.S. patent #5087838

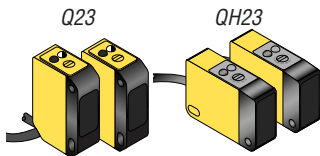

Visible red, 680 nm

## Q23 & QH23 Opposed Mode Emitter (E) and Receiver (R)

Models	Range	Cable	Supply Voltage	Output Type	Excess Gain	Beam Pattern
Q236E QH236E Q236EQ QH236EQ	8 m (26ft)	2 m (6.5 ft) 2 m (6.5 ft) 4-Pin Pico QD 4-Pin Pico QD	10-30V dc	Complementary Solid-state NPN		Effective Beam: 5.3 mm 
Q23SN6R QH23SN6R Q23SN6RQ QH23SN6RQ		2 m (6.5 ft) 2 m (6.5 ft) 4-Pin Pico QD 4-Pin Pico QD				
Q23SP6R QH23SP6R Q23SP6RQ QH23SP6RQ		2 m (6.5 ft) 2 m (6.5 ft) 4-Pin Pico QD 4-Pin Pico QD				

# Q23 and QH23 Series

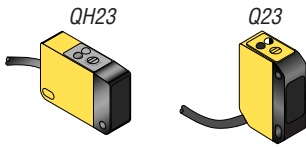

NOTE: Retroreflective range is specified using one model BRT-3 retroreflector (3-inch diameter). Actual sensing range may be more or less than specified, depending upon the efficiency and reflective area of the retroreflector(s) in use. See the Banner Photoelectric Sensors catalog for more information on available retroreflectors.



Visible red, 680 nm

## Q23 & QH23 Polarized Retroreflective Mode

Models	Range	Cable	Supply Voltage	Output Type	Excess Gain	Beam Pattern
<b>Q23SN6LP</b> <b>QH23SN6LP</b> <b>Q23SN6LPQ</b> <b>QH23SN6LPQ</b>	100 mm to 2 m (4 to 80 in)	2 m (6.5 ft) 2 m (6.5 ft) 4-Pin Pico QD 4-Pin Pico QD	10-30V dc	Complementary Solid-state NPN		
<b>Q23SP6LP</b> <b>QH23SP6LP</b> <b>Q23SP6LPQ</b> <b>QH23SP6LPQ</b>		2 m (6.5 ft) 2 m (6.5 ft) 4-Pin Pico QD 4-Pin Pico QD		Complementary Solid-state PNP		

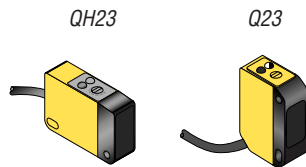

Visible red, 680 nm

## Q23 & QH23 Diffuse Mode

Models	Range	Cable	Supply Voltage	Output Type	Excess Gain	Beam Pattern
					Performance based on 90% reflectance white test card	
<b>Short Range</b>						
<b>Q23SN6D</b> <b>QH23SN6D</b> <b>Q23SN6DQ</b> <b>QH23SN6DQ</b>	Optimum: 2 - 50 mm (.1 - 2 in)	2 m (6.5 ft) 2 m (6.5 ft) 4-Pin Pico QD 4-Pin Pico QD	10-30V dc	Complementary Solid-state NPN		
<b>Q23SP6D</b> <b>QH23SP6D</b> <b>Q23SP6DQ</b> <b>QH23SP6DQ</b>	Maximum: 200 mm (8 in)	2 m (6.5 ft) 2 m (6.5 ft) 4-Pin Pico QD 4-Pin Pico QD		Complementary Solid-state PNP		
<b>Long Range</b>						
<b>Q23SN6DL</b> <b>QH23SN6DL</b> <b>Q23SN6DLQ</b> <b>QH23SN6DLQ</b>	Optimum: 30 - 300 mm (1.2 - 12 in)	2 m (6.5 ft) 2 m (6.5 ft) 4-Pin Pico QD 4-Pin Pico QD	10-30V dc	Complementary Solid-state NPN		
<b>Q23SP6DL</b> <b>QH23SP6DL</b> <b>Q23SP6DLQ</b> <b>QH23SP6DLQ</b>	Maximum: 800 mm (32 in)	2 m (6.5 ft) 2 m (6.5 ft) 4-Pin Pico QD 4-Pin Pico QD		Complementary Solid-state PNP		

# Q23 and QH23 Series

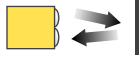

Visible red, 680 nm

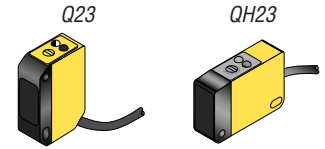

Q23 & QH23 Convergent						
Models	Focus	Cable	Supply Voltage	Output Type	Excess Gain	Beam Pattern
<b>Q23SN6CV50</b> <b>QH23SN6CV50</b> <b>Q23SN6CV50Q</b> <b>QH23SN6CV50Q</b>	50 mm (2 in)	2 m (6.5 ft) 2 m (6.5 ft) 4-Pin Pico QD 4-Pin Pico QD	10-30V dc	Complementary Solid-state NPN		
<b>Q23SP6CV50</b> <b>QH23SP6CV50</b> <b>Q23SP6CV50Q</b> <b>QH23SP6CV50Q</b>		2 m (6.5 ft) 2 m (6.5 ft) 4-Pin Pico QD 4-Pin Pico QD		Complementary Solid-state PNP		

**For All Q23 & QH23 Sensors:**

- i) 9 m (30 ft) cables are available by adding suffix “W/30” to the model number of any cabled sensor (e.g. - Q23SN6LP W/30)
- ii) All Q23 QD models have a 4-pin pico-style connector on a 150 mm (6 in) cable pigtail.
- iii) A model with a QD connector requires an optional mating cable. See Accessories for more information.

# Q23 and QH23 Series

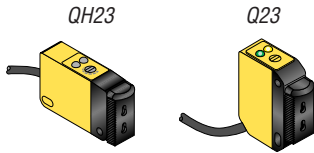

Visible red, 680 nm

Q23 & QH23 Plastic Fiber Optic						
Models	Range	Cable	Supply Voltage	Output Type	Excess Gain	Beam Pattern
					Diffuse mode performance based on 90% reflectance white test card	
<b>Standard Speed: 1 ms Response</b>						
<b>Q23SN6FP</b> <b>QH23SN6FP</b> <b>Q23SN6FPQ</b> <b>QH23SN6FPQ</b>	Range varies by sensing mode and fiber optics used	2 m (6.5 ft) 2 m (6.5 ft) 4-Pin Pico QD 4-Pin Pico QD	10-30V dc	Complementary Solid-state NPN		
<b>Q23SP6FP</b> <b>QH23SP6FP</b> <b>Q23SP6FPQ</b> <b>QH23SP6FPQ</b>		2 m (6.5 ft) 2 m (6.5 ft) 4-Pin Pico QD 4-Pin Pico QD			Complementary Solid-state PNP	
<b>High Speed: 100 µs Response</b>						
<b>Q23SN6FPY</b> <b>QH23SN6FPY</b> <b>Q23SN6FPYQ</b> <b>QH23SN6FPYQ</b>	Range varies by sensing mode and fiber optics used	2 m (6.5 ft) 2 m (6.5 ft) 4-Pin Pico QD 4-Pin Pico QD	10-30V dc	Complementary Solid-state NPN		
<b>Q23SP6FPY</b> <b>QH23SP6FPY</b> <b>Q23SP6FPYQ</b> <b>QH23SP6FPYQ</b>		2 m (6.5 ft) 2 m (6.5 ft) 4-Pin Pico QD 4-Pin Pico QD			Complementary Solid-state PNP	

## For Q23 Plastic Fiber Sensing Mode:

- The opposed range of Q23FP sensors using 1 mm (0.4 in) plastic fibers may be extended using optional lens pairs. A pair of model L2 lenses extends the opposed range to 2 m (80 in). A pair of model L08FP lenses extends opposed range to 3 m (10 ft). See the photoelectric sensors catalog for lens details.
- Diffuse mode sensing with Q23FPY models is generally not recommended due to low excess gain. If in doubt about sensing performance, contact the factory Application Engineering Department or your local Banner Sales Engineer to discuss diffuse mode applications.

# Q23 and QH23 Series

Q23 & QH23 Product Specifications	
<b>Supply Voltage and Current</b>	10 to 30V dc (10% maximum ripple) at less than 25 mA for diffuse, retro, and fiber optic models (exclusive of load) Opposed emitters and receivers draw 20 mA each
<b>Supply Protection Circuitry</b>	Protected against reverse polarity and transient voltages
<b>Output Configuration</b>	Solid-state dc complementary outputs: Q(H)23SN6xx models = NPN sinking, N.O. (normally open) & N.C. (normally closed) complementary Q(H)23SP6xx models = PNP sourcing, N.O. & N.C. complementary Light operate: N.O. output conducts when the sensor sees its own modulated light source Dark operate: N.C. output conducts when the sensing beam is blocked The N.C. output may be used as an alarm output, depending upon hookup to the power supply (see hookup diagrams)
<b>Output Rating</b>	150 mA maximum each in standard hookup; when wired for alarm output, the total load may not exceed 150 mA <b>Off-state leakage current</b> less than 1 microamp at 30V dc <b>Output saturation voltage</b> less than 1 volt at 10mA dc; less than 1.5V at 150 mA dc
<b>Output Protection Circuitry</b>	Protected against false pulse on power-up, transient voltages, and continuous overload or short-circuit of outputs
<b>Output Response Time</b>	1 millisecond “on” and “off” (except for Q23FPY high-speed sensors which have 100 microsecond response time); no false pulse on power-up (NOTE: 100 millisecond delay on power-up: outputs are non-conducting during this time.)
<b>Repeatability</b>	<b>All Opposed Modes:</b> 0.13 ms; <b>Retro and Diffuse:</b> 0.25 ms; <b>FPY High speed Plastic Fiber Optic:</b> 25 microseconds Response time and repeatability specifications are independent of signal strength.
<b>Adjustments</b>	SENSITIVITY control (single-turn, o-ring sealed potentiometer)
<b>Indicators</b>	Sensors except opposed mode emitters have two LEDs: GREEN glowing steadily = dc power “on” GREEN flashing = output overload YELLOW glowing steadily = normally open output is conducting YELLOW flashing = marginal excess gain (1 - 1.5x), light condition; flashing YELLOW corresponds to “on” state of alarm output Emitters have green power “on” indicator
<b>Construction</b>	Yellow and black ABS housing, with acrylic lens and clear ABS top cover, completely sealed. Stainless steel mounting bracket and M3 mounting hardware are supplied
<b>Environmental Rating</b>	Meets NEMA standards 1, 2, 3, 3S, 4, 4X, 6, 12, and 13; IEC IP67. Housing materials rated UL 94 V-0
<b>Connections</b>	PVC-jacketed 4-conductor 2 m (6.5 ft) or 9 m (30 ft) cables, or 6-inch pigtail with 4-pin pico-style quick disconnect (QD) fitting are available. Mating QD cables are ordered separately. See Accessories.
<b>Operating Temperature</b>	<b>Temperature:</b> -20° to +55°C (-5° to +131°F) <b>Maximum relative humidity:</b> 90% at 50°C (non-condensing)
<b>Application Note</b>	To avoid damage to the sensor caused by static discharge (ESD), use the plastic screwdriver supplied with each sensor (included in the hardware packet) to adjust the SENSITIVITY control. Otherwise, use a screwdriver with an insulated handle.
<b>Certifications</b>	

## Quick Disconnect (QD) Option

Q23 & QH23 sensors are sold either with a 2 m (6.5 ft) or 9 m (30 ft) attached PVC-covered cable or with a 4-pin pico-style QD connector on a 150 mm (6 in) cable pigtail.

Q23 & QH23 QD sensors are identified by the letter “Q” in their model number suffix. Mating cables for QD sensors are model PKG4-2 (straight connector) or PKW4-2 (right-angled connector). Cables are supplied in a standard length of 2 m (6.5 ft). For more information on QD cable, see Accessories.

# Q23 and QH23 Series

## Q23 & QH23 Hookup Diagrams

### Sensors with NPN (Sinking) Outputs Standard Hookup

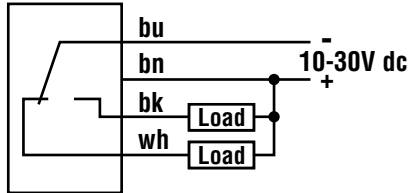

### Alarm Hookup

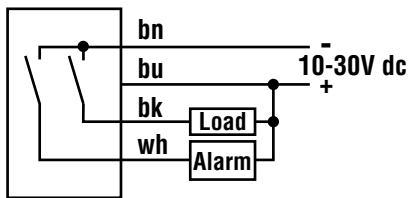

### Sensors with PNP (Sourcing) Outputs Standard Hookup

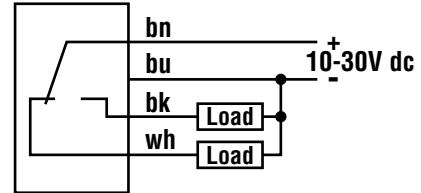

### Alarm Hookup

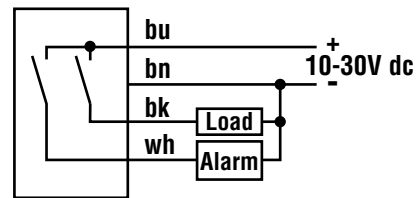

### Emitters

Note: No connection to bk and wh wires of QD cable.

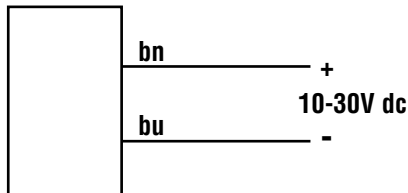

### 4-Pin Pico-Style Pin-out (Connector on Cable Shown)

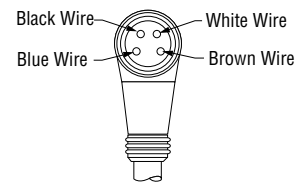

NOTE: Hookups are the same for either an integral or QD cable. QD connector pin configuration is, as follows:

### Q23 Pigtail Quick Disconnect

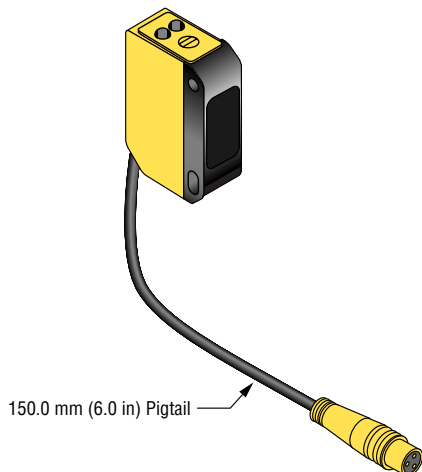

### QH23 Pigtail Quick Disconnect

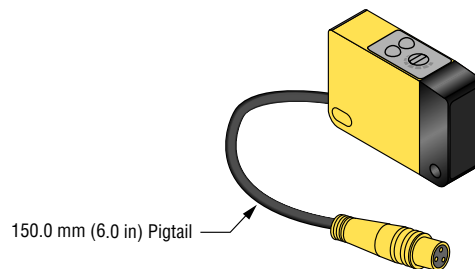

# Q23 and QH23 Series

## Q23 Dimension Information

### Q23 Sensor - Opposed, Diffuse, and Retroreflective Modes (model suffix E, R, D, & LP)

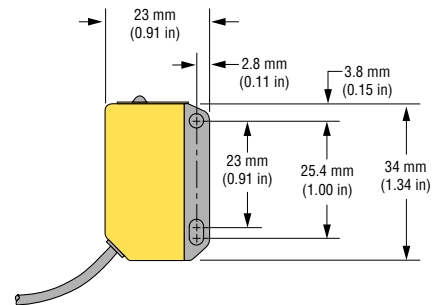
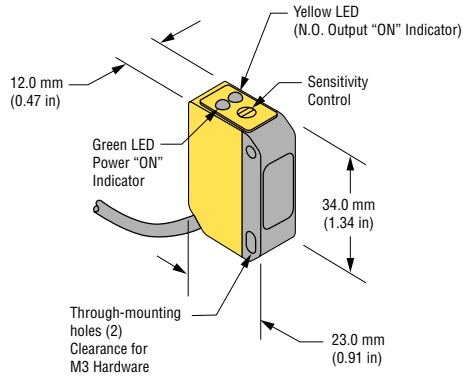

### Q23 Sensor - Convergent Mode (model suffix CV)

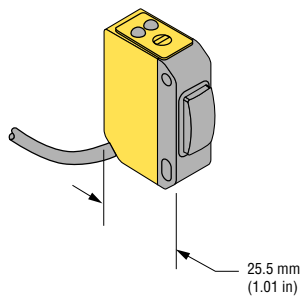

### Q23 Sensor - Plastic Fiber Optic (model suffix FP & FPY)

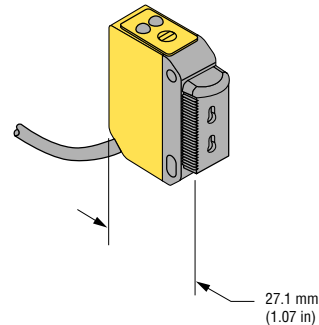

### Q23 Mounting Bracket (included with sensor)

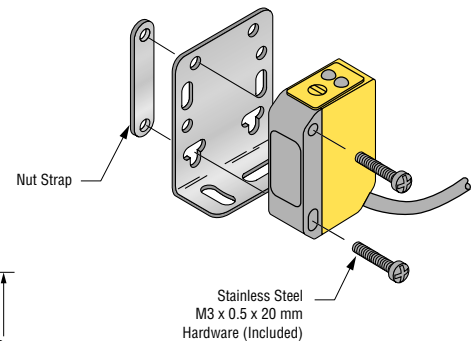
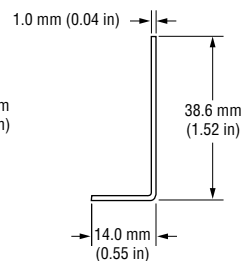
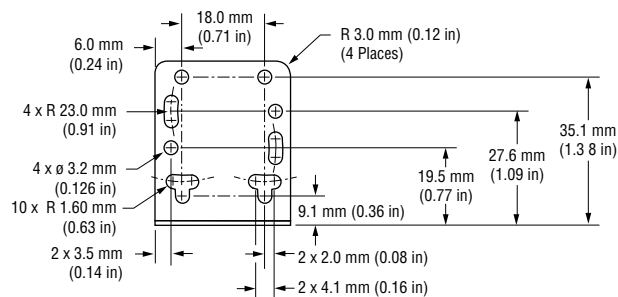
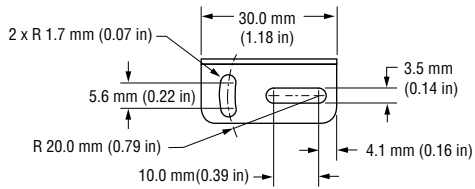

NOTE: Use of lockwashers is optional

# Q23 and QH23 Series

## QH23 Dimension Information

### QH23 Sensor - Opposed, Diffuse, and Retroreflective Modes (model suffix E, R, D, & LP)

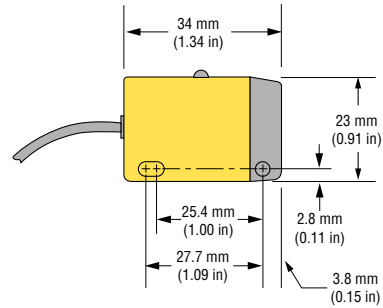
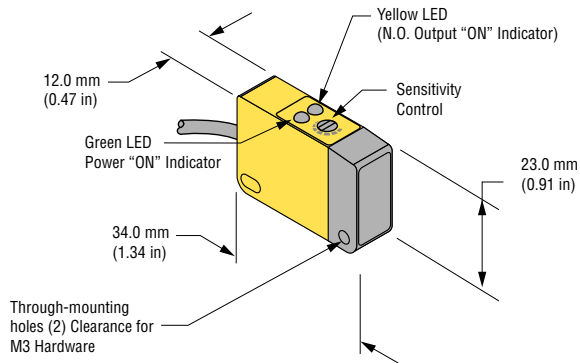

### QH23 Sensor - Convergent (model suffix CV)

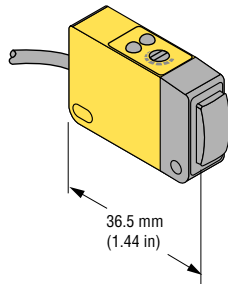

### QH23 Sensor - Plastic Fiber Optic (model suffix FP & FPY)

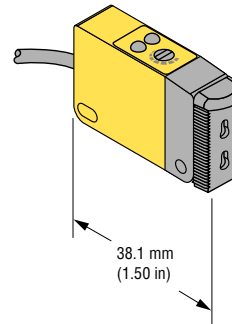

### QH23 Mounting Bracket (included with sensor)

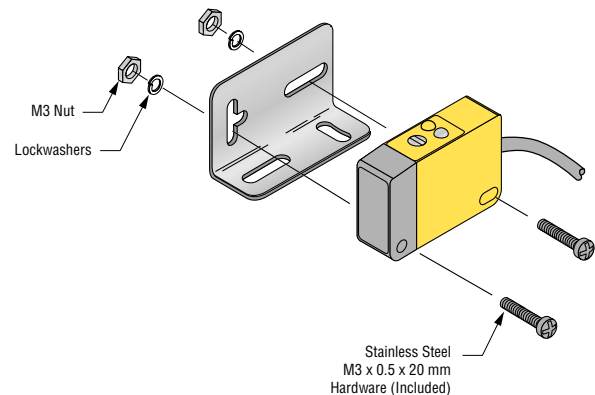
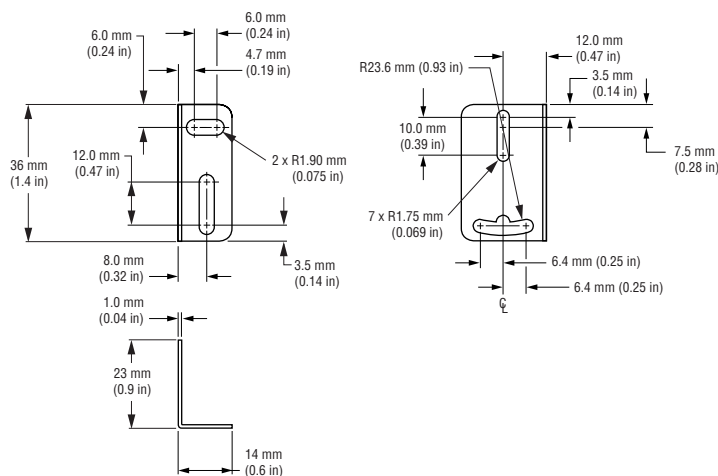



# Q23 and QH23 Series

## Q23 Accessories

### Q23 & QH23 Modifications

Model Suffix	Modification	Description	Example of Model Number
W/30	9 m (30 ft) cable	All Q23 sensors may be ordered with an integral 9 m (30 ft) cable in place of the standard 2 m (6.5 ft) cable	Q23SP6D W/30

### Quick Disconnect (QD) Cables

The following is a selection of cables available for the EZ-BEAM QD models

Style	Model	Length	Dimensions
Pico Style straight	PKG4-2	2 m (6.5 ft)	
Pico Style right angle	PKW4-2		

# Q23 and QH23 Series

## Optional Mounting Bracket Information

**SMB46L**

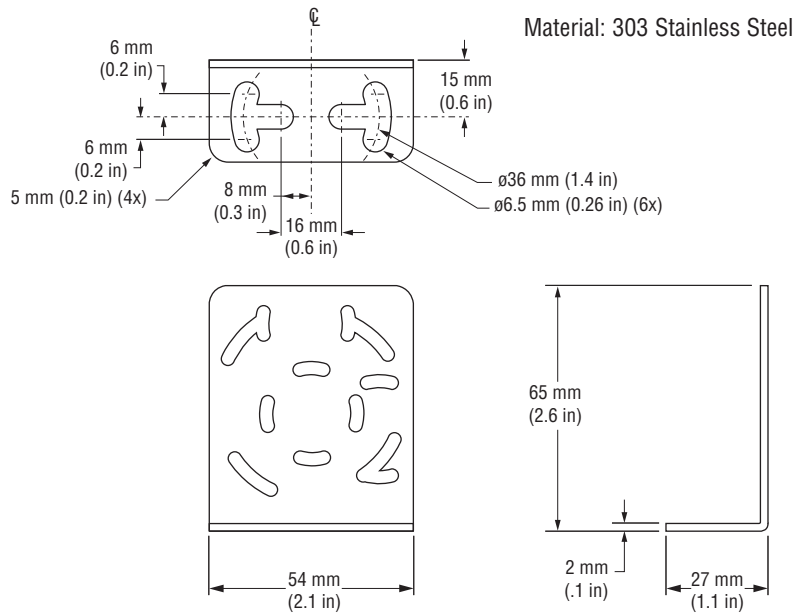
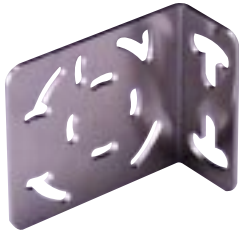

**SMB46S**

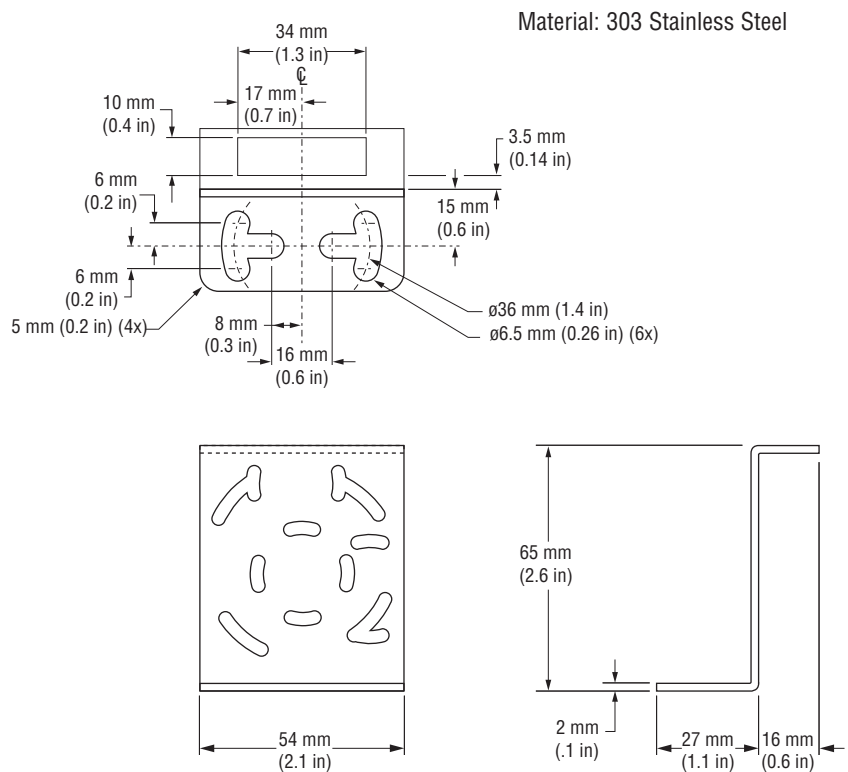

# Q23 and QH23 Series

## Optional Mounting Bracket Information

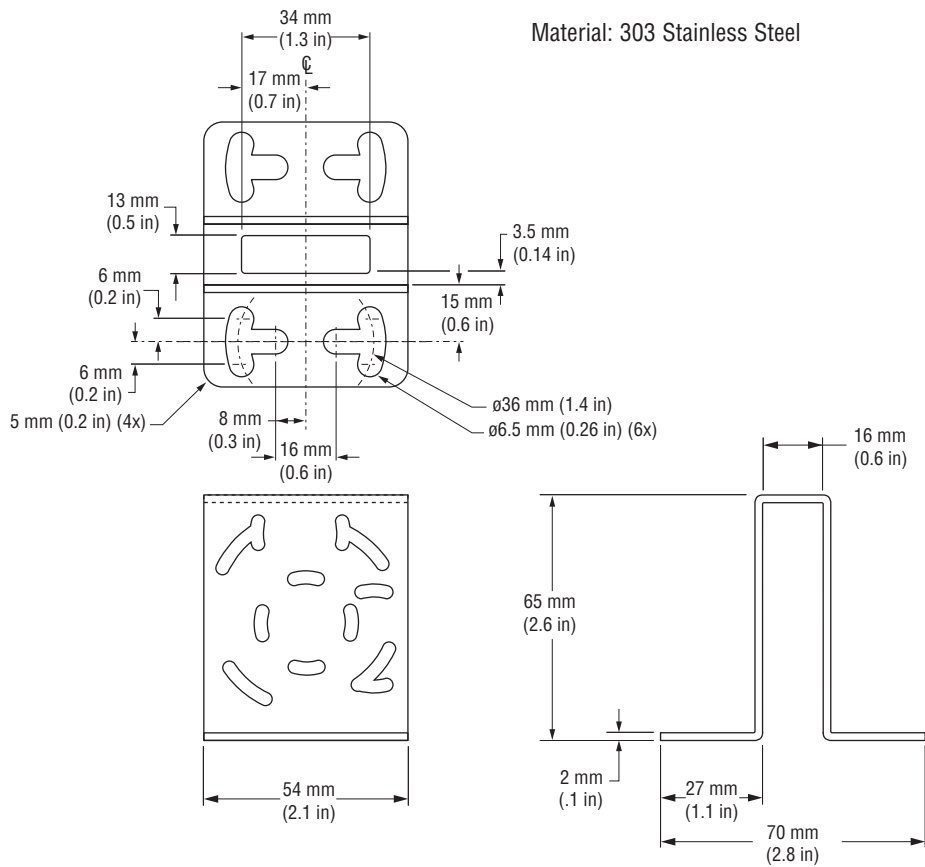

### Q23 Mounting Configurations

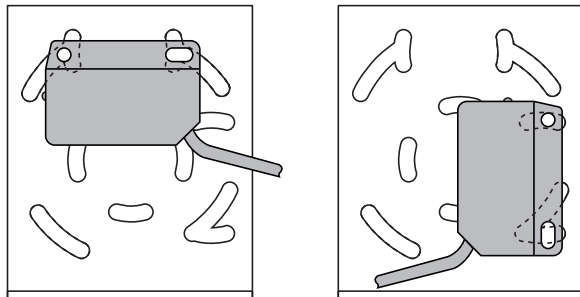

### QH23 Mounting Configurations

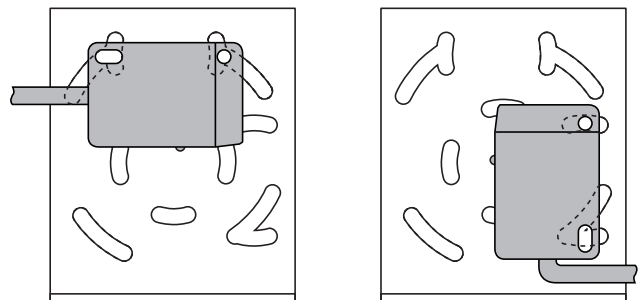

# Q23 and QH23 Series

---



**WARRANTY:** Banner Engineering Corporation warrants its products to be free from defects for one year. Banner Engineering Corporation will repair or replace, free of charge, any product of its manufacture found to be defective at the time it is returned to the factory during the warranty period. This warranty does not cover damage or liability for the improper application of Banner products. This warranty is in lieu of any other warranty either expressed or implied.



**WARNING** These photoelectric presence sensors do NOT include the self-checking redundant circuitry necessary to allow their use in personnel safety applications. A sensor failure or malfunction can result in either an energized or a de-energized sensor output condition.

Never use these products as sensing devices for personnel protection. Their use as a safety device may create an unsafe condition which could lead to serious injury or death.

Only MICRO-SCREEN™, MINI-SCREEN®, MULTI-SCREEN®, MACHINE-GUARD™ and PERIMETER-GUARD™ Systems, and other systems so designated, are designed to meet OSHA and ANSI machine safety standards for point-of-operation guarding devices. No other Banner sensors or controls are designed to meet these standards, and they must NOT be used as sensing devices for personnel protection.