

# Q45BB6 Series Sensors



## Datasheet

10 V dc to 30 V dc Photoelectric Sensors With Sinking and Sourcing Solid-State Outputs



- Advanced one-piece photoelectric sensors with outstanding optical performance and extremely rugged design
- Operate from: 10 V dc to 30 V dc
- Bipolar NPN (sinking)/PNP (sourcing) outputs on all models
- Multiple sensing modes available: opposed, diffuse, retroreflective, and convergent, plus glass and plastic fiber optic models
- Selectable light/dark operate
- Versatile plug-in modules available for output timing logic and/or signal strength display
- Highly visible Power, Signal (AID™ System <sup>1</sup>), and Output indicator LEDs
- Choice of prewired 2 m (6.5 ft) or 9 m (30 ft) unterminated cable, plus Mini-style or Euro-style quick-disconnect fittings
- Versatile mounting options
- Designed to withstand 1200 psi washdown; exceeds its NEMA 6P and IEC IP67 rating



### WARNING: Not To Be Used for Personnel Protection

**Never use this device as a sensing device for personnel protection. Doing so could lead to serious injury or death.** This device does not include the self-checking redundant circuitry necessary to allow its use in personnel safety applications. A sensor failure or malfunction can cause either an energized or de-energized sensor output condition.

## Models

To order the 9 m (30 ft) cable models, add the suffix "W/30" to the cabled model number. Models with a quick disconnect (QD) connector require a mating cable.

### Opposed-Mode Emitter (E) and Receiver (R) Models

Because of their extremely high excess gain, these opposed-mode sensors are an excellent option for sensing in contaminated or dirty areas, and are also the best choice for long-range sensing.

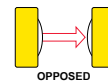

Infrared, 880 nm

Models	Range	Cable	Supply Voltage	Output Type
Q456E Emitter	60 m (200 ft)	2-wire 2 m (6.5 ft) cable	10 V dc to 30 V dc	Bipolar NPN/PNP
Q45BB6R Receiver		4-wire 2 m (6.5 ft) cable		
Q456EQ Emitter		4-Pin Mini-style QD		
Q45BB6RQ Receiver				
Q456EQ5 Emitter		4-pin Euro-style QD		
Q45BB6RQ5 Receiver				

<sup>1</sup> U.S. Patent no. 4356393



## Retroreflective-Mode Models

The visible red sensing beam of these sensors makes them very easy to align. Model Q45BB6LP polarizes the emitted light and filters out unwanted reflections, making sensing possible in applications otherwise considered unsuited to retroreflective sensing. Specified using the model BRT-3 3-inch reflector (go to [www.bannerengineering.com](http://www.bannerengineering.com) additional information).

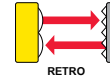

Visible red, 680 nm  
(non-polarized)



Visible red, 680 nm  
(polarized)

Non-Polarized				
Models	Range	Cable	Supply Voltage	Output Type
Q45BB6LV	0.08 to 9 m (3 in to 30 ft)	4-wire 2 m (6.5 ft) cable	10 V dc to 30 V dc	Bipolar NPN/PNP
Q45BB6LVQ		4-Pin Mini-style QD		
Q45BB6LVQ5		4-Pin Euro-style QD		
Polarized				
Models	Range	Cable	Supply Voltage	Output Type
Q45BB6LP	0.15 to 6 m (6 in to 20 ft)	4-wire 2 m (6.5 ft) cable	10 V dc to 30 V dc	Bipolar NPN/PNP
Q45BB6LPQ		4-Pin Mini-style QD		
Q45BB6LPQ5		4-Pin Euro-style QD		

## Diffuse-Mode Models

These diffuse-mode models detect objects by sensing the reflection of their own emitted light. Ideal for use when the reflectivity and profile of the object to be sensed are sufficient to return a large percentage of emitted light back to the sensor. Model Q45BB6DX is the first choice for diffuse-mode applications when there are no background objects to falsely return light.

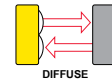

Infrared, 880 nm

Short Range				
Models	Range	Cable	Supply Voltage	Output Type
Q45BB6D	45 cm (18 in)	4-wire 2 m (6.5 ft) cable	10 V dc to 30 V dc	Bipolar NPN/PNP
Q45BB6DQ		4-Pin Mini-style QD		
Q45BB6DQ5		4-Pin Euro-style QD		
Long Range				
Models	Range	Cable	Supply Voltage	Output Type
Q45BB6DL	1.8 m (6 ft)	4-wire 2 m (6.5 ft) cable	10 V dc to 30 V dc	Bipolar NPN/PNP
Q45BB6DLQ		4-Pin Mini-style QD		
Q45BB6DLQ5		4-Pin Euro-style QD		
High Power				
Models	Range	Cable	Supply Voltage	Output Type
Q45BB6DX	3 m (10 ft)	4-wire 2 m (6.5 ft) cable	10 V dc to 30 V dc	Bipolar NPN/PNP
Q45BB6DXQ		4-Pin Mini-style QD		
Q45BB6DXQ5		4-Pin Euro-style QD		

## Convergent-Mode Models

These sensors are ideal for reflective sensing of very small parts or profiles, and can accurately sense the position of parts approaching from the side. Ignores all but highly reflective objects that are outside the sensing range.

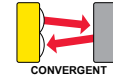

Visible red, 680 nm

Models	Focus	Cable	Supply Voltage	Output Type
Q45BB6CV	38 mm (1.5 in)	4-wire 2 m (6.5 ft) cable	10 V dc to 30 V dc	Bipolar NPN/PNP
Q45BB6CVQ	Spot Size at Focus: 1.3 mm (0.05 in)	4-Pin Mini-style QD		
Q45BB6CVQ5		4-Pin Euro-style QD		
Q45BB6CV4	100 mm (4 in)	4-wire 2 m (6.5 ft) cable	10 V dc to 30 V dc	Bipolar NPN/PNP
Q45BB6CV4Q	Spot Size at Focus: 1.5 mm (0.06 in)	4-Pin Mini-style QD		
Q45BB6CV4Q5		4-Pin Euro-style QD		

## Glass Fiber Optic Models

These models are an excellent choice for glass fiber optic applications where faster sensor response is not important. Their high excess gain means that opposed individual fibers can operate reliably in many very hostile environments. Also, special miniature bifurcated fiber optic assemblies with bundle sizes as small as 0.5 mm (.020 in) diameter may be used successfully for diffuse-mode sensing when using sensor model Q45BB6F(Q). For more information on compatible glass fiber optics, go to [www.bannerengineering.com](http://www.bannerengineering.com).

**Range:** Range varies by sensing mode and fiber optics used.

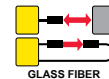

Infrared, 880 nm and  
Visible red, 650 nm

Infrared, 880 nm				
Models	Cable	Supply Voltage	Output Type	
Q45BB6F	4-wire 2 m (6.5 ft) cable	10 V dc to 30 V dc	Bipolar NPN/PNP	
Q45BB6FQ	4-Pin Mini-style QD			
Q45BB6FQ5	4-Pin Euro-style QD			
Visible Red, 650 nm				
Models	Cable	Supply Voltage	Output Type	
Q45BB6FV	4-wire 2 m (6.5 ft) cable	10 V dc to 30 V dc	Bipolar NPN/PNP	
Q45BB6FVQ	4-Pin Mini-style QD			
Q45BB6FVQ5	4-Pin Euro-style QD			

## Plastic Fiber Optic Models

Lower in cost than glass fiber optics, plastic fiber optics are ideal for use in situations where environmental conditions allow (for example, low levels of acids, alkalis, and solvents). Most are easily cut to length in the field, and are available in a variety of sensing end styles. For more information on compatible plastic fiber optics, go to [www.bannerengineering.com](http://www.bannerengineering.com).

**Range:** Range varies by sensing mode and fiber optics used.

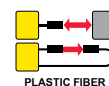

Visible red, 660 nm

Models	Cable	Supply Voltage	Output Type	
Q45BB6FP	4-wire 2 m (6.5 ft) cable	10 V dc to 30 V dc	Bipolar NPN/PNP	
Q45BB6FPQ	4-Pin Mini-style QD			
Q45BB6FPQ5	4-Pin Euro-style QD			

## Overview

Status indicator LEDs for power, signal, and output are clearly visible beneath a raised dome in the sensor's transparent o-ring-sealed polycarbonate cover. Also located beneath the sensor's o-ring-sealed cover are controls for light/dark operate selection and the sensitivity adjustment.

- The power indicator (green) lights when power is applied to the sensor.
- The signal indicator (red) lights when the sensor sees its modulated light source and pulses at a rate proportional to the strength of the received light signal; this is the AID™ Alignment Indicating Device<sup>2</sup>.
- The output indicator (amber) lights when the sensor's output is conducting. This indicator is especially useful when a timing logic module is used and signal and output conditions are not concurrent.



1. Sensitivity adjustment
2. LEDs
  - Green LED: Power on indicator
  - Red LED: Signal indicator
  - Amber LED: Output status indicator
3. Optional LED signal strength display
4. Optional timing adjustment
5. Optional timing adjustment
6. Light/dark operate switch

## Wiring Diagrams

Q45BB6 Sensors with Attached Cable

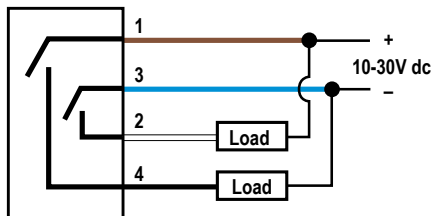

Q456E Emitters with Attached Cable

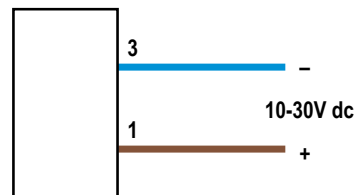

Key:

- 1= Brown
- 2= White
- 3= Blue
- 4= Black



**NOTE:** Wiring for quick disconnect (QD) models (model suffix Q and Q5) are functionally identical.

<sup>2</sup> US patent no. 4356393

## Specifications

### Supply Voltage and Current

10 V dc to 30V dc (10% maximum ripple), at less than 50 mA (exclusive of load)

### Supply Protection Circuitry

Protected against reverse polarity and transient voltages

### Output Configuration

Bipolar: one current sourcing (PNP) and one current sinking (NPN) open-collector transistor

### Output Rating

250 mA maximum each output up to 50 °C, derated to 150 mA at 70 °C (derates 5 mA/°C)  
 Off-state leakage current less than 1 µA  
 Output saturation voltage (both outputs) less than 1 V at 10 mA and less than 2 V at 250 mA

### Output Protection Circuitry

Protected against false pulse on power-up and continuous overload or short circuit of outputs

### Output Response Time

Opposed mode: 2 milliseconds ON, 1 millisecond OFF  
 All other sensing modes: 2 milliseconds ON/OFF



**NOTE:** 100 millisecond delay on power-up. Output is non-conducting during this time.

### Repeatability

Opposed mode: 0.25 milliseconds  
 All other sensing modes: 0.5 milliseconds  
 Response time and repeatability specifications are independent of signal strength.

### Adjustments

Beneath sensor's transparent cover: Light/Dark Operate select switch and multi-turn Sensitivity control (allows precise sensitivity setting – turn clockwise to increase gain). Optional logic and logic/display modules have adjustable timing functions (see [Output Timing Logic and Signal Strength Display Modules](#) on page 9)

### Indicators

Indicator LEDs are clearly visible beneath a raised transparent Lexan® dome on top of the sensor.

Power (green) LED lights whenever 10 V dc to 30V dc power is applied, and flashes to indicate output overload or output short circuit  
 Signal (red) AID™ System LED lights whenever the sensor sees its modulated light source, and pulses at a rate proportional to the strength of the received light signal

Load (amber) LED lights whenever the output is energized  
 Optional 7-element LED signal strength display modules

### Construction

Molded reinforced thermoplastic polyester housing, o-ring-sealed transparent Lexan® cover, molded acrylic lenses, and stainless steel hardware. Designed to withstand 1200 psi washdown. The base of the cabled models has a 1/2-inch NPS integral internal conduit thread.

### Environmental Rating

NEMA 6, IEC IP67

### Connections

PVC-jacketed 2 m (6.5 ft) or 9 m (30 ft) cables; or 4-pin Mini-style ("Q" suffix models) or 4-pin Euro-style ("Q5" suffix models) quick-disconnect (QD) fittings are available. QD cables are ordered separately.

### Operating Conditions

**Temperature:** -40 °C to +70 °C (-40 °F to +158 °F)  
 90% at +50 °C maximum relative humidity (non-condensing)

### Application Notes

Optional output timing modules are available. See [Output Timing Logic and Signal Strength Display Modules](#) on page 9.

### Certifications



## Dimensions

### Opposed, Retro, and Diffuse Sensing Modes (Model Suffix E, R, D, DL, DX, LP, and LV)

#### Cabled Models

#### Mini-Style Quick-Disconnect Models

#### Euro-Style Quick Disconnect Models

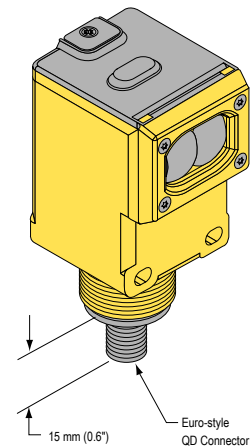
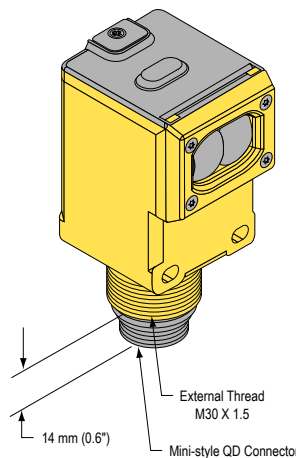
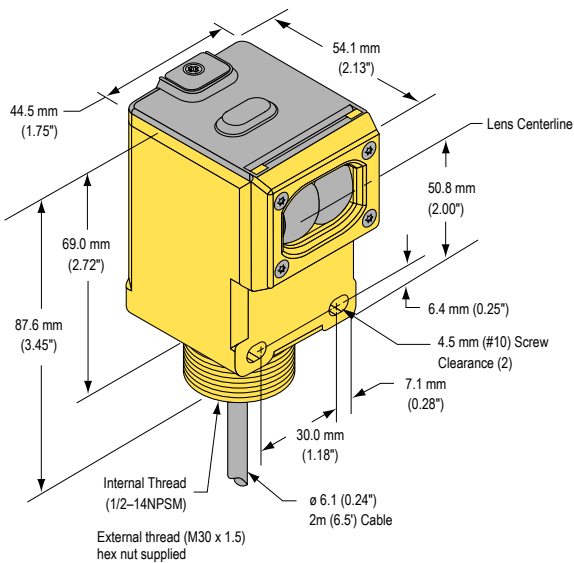

Lexan® is a registered trademark of General Electric Co.

<b>Convergent Sensor Models</b> (CV and CV4)	<b>Glass Fiber Optic Models</b> (F and FV)	<b>Plastic Fiber Optic Models</b> (FP)
---	---	---

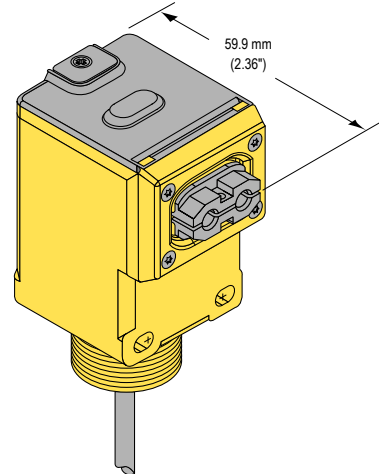
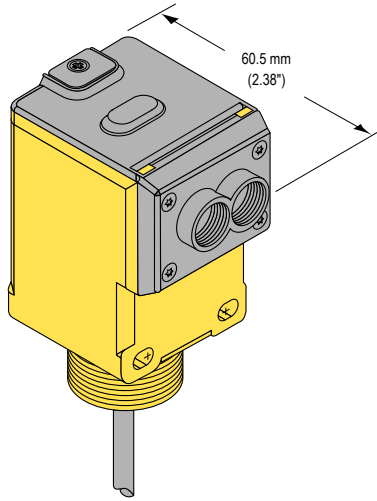
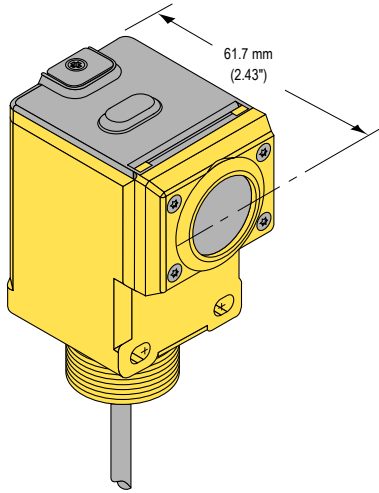

**Performance Curves**

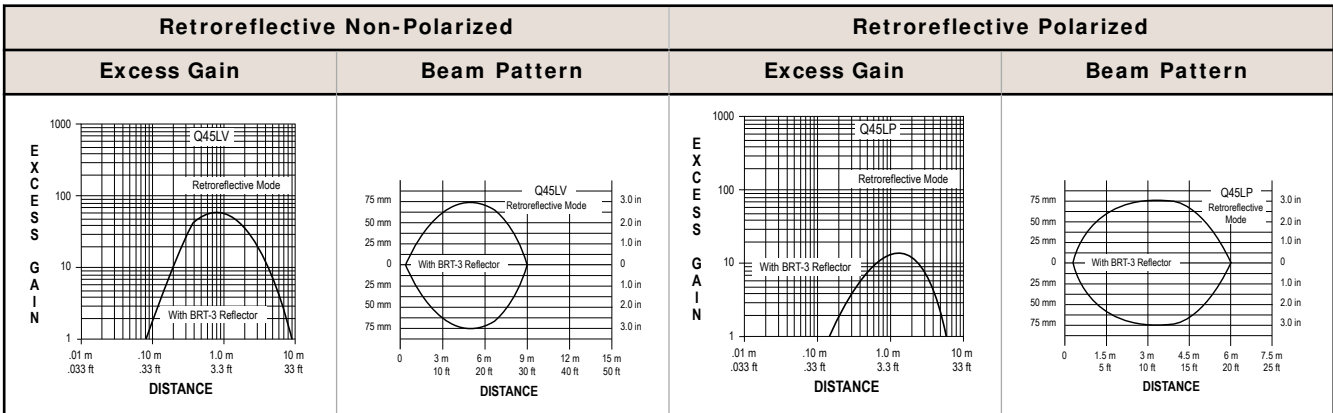
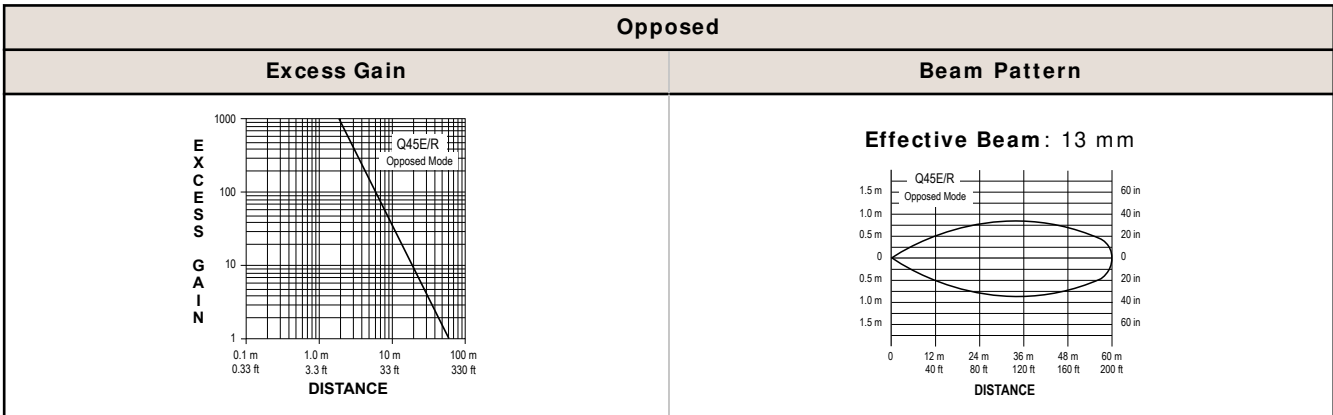

Diffuse-mode performance curves are based on a 90% reflectance white test card.

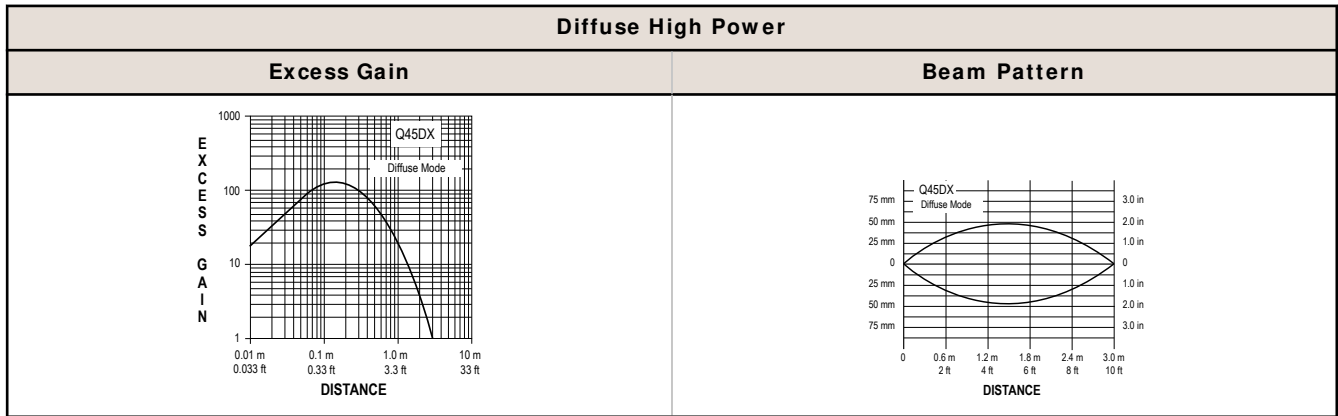
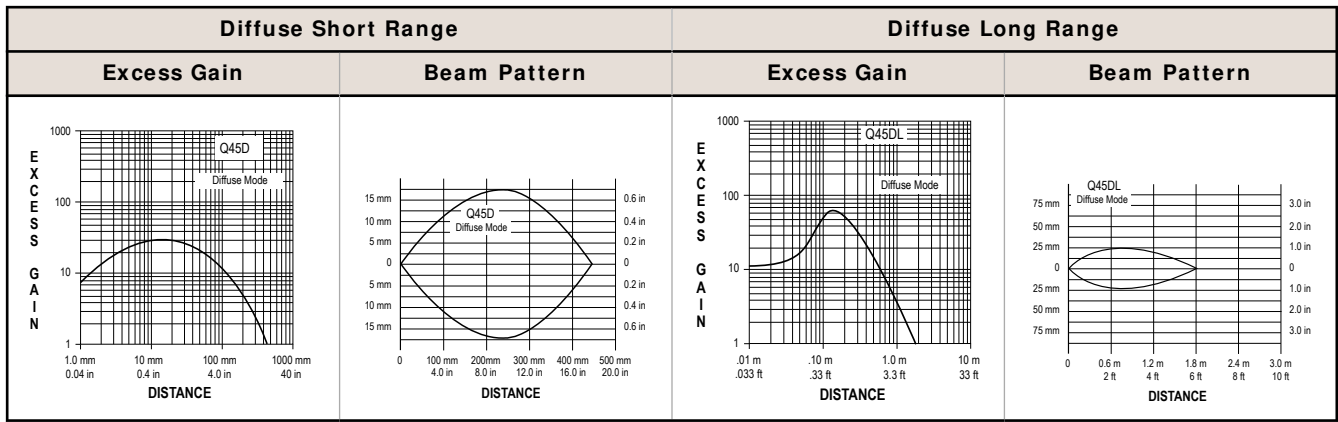

Convergent mode performance curves are based on a 90% reflectance white test card.

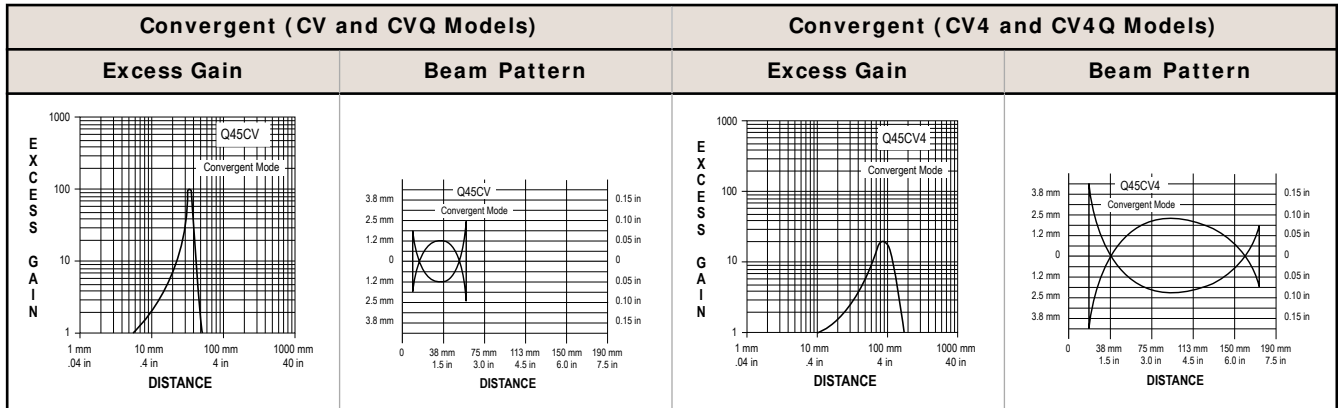

Glass fiber optic diffuse mode performance curves are based on a 90% reflectance white test card.

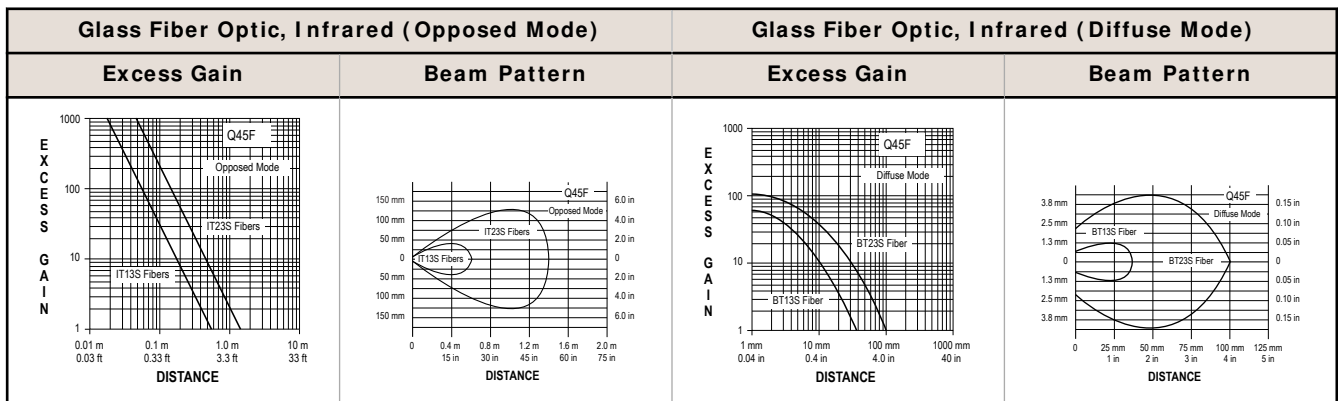

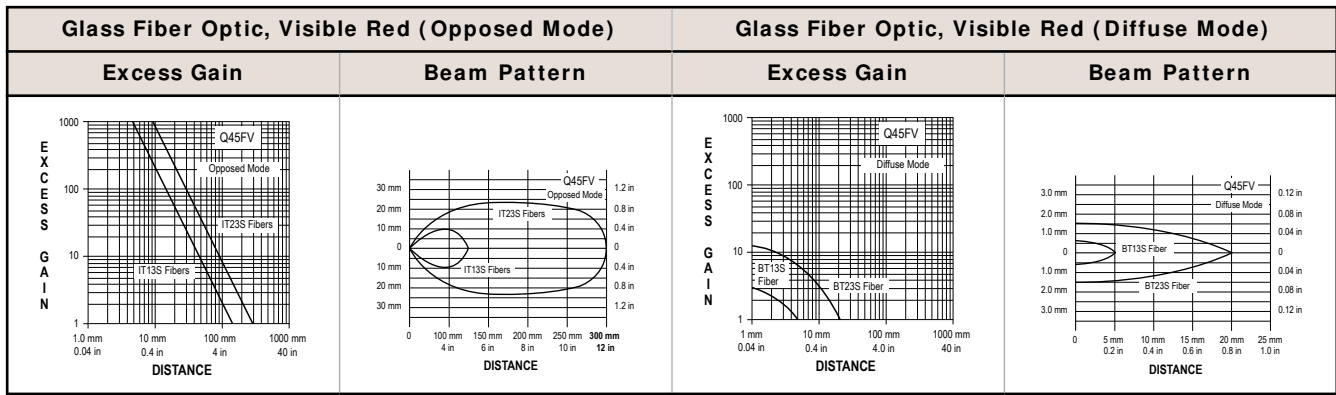

Plastic fiber optic Diffuse mode performance curves are based on a 90% reflectance white test card.

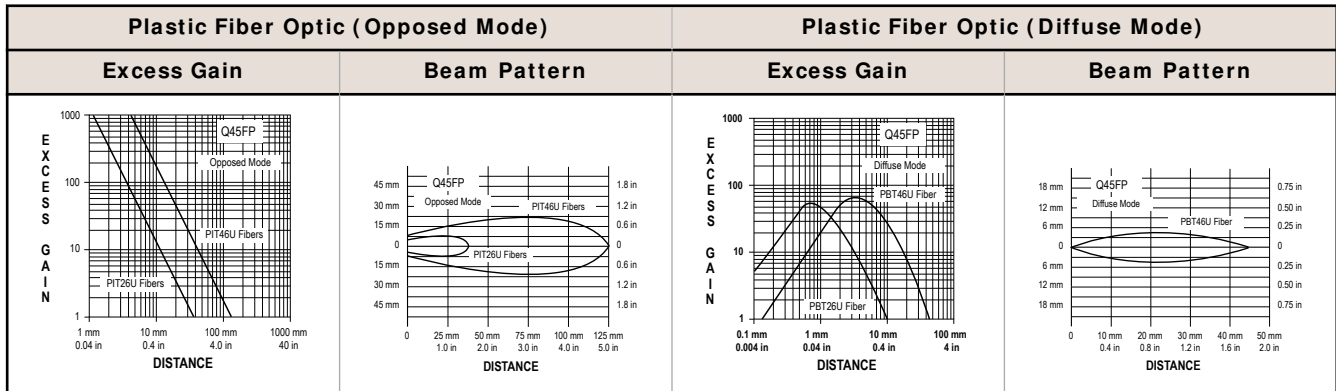

## Accessories

### Corsets

4-Pin Threaded M12/ Euro-Style Cordsets				
Model	Length	Style	Dimensions	Pinout (Female)
MQDC-406	1.83 m (6 ft)	Straight		<p>1 = Brown 2 = White 3 = Blue 4 = Black</p>
MQDC-415	4.57 m (15 ft)			
MQDC-430	9.14 m (30 ft)			
MQDC-450	15.2 m (50 ft)			

4-Pin Mini-Style Cordsets				
Model	Length	Style	Dimensions	Pinout (Female)
MBCC-406	1.83 m (6 ft)	Straight		<p>1 = Brown 2 = White 3 = Blue 4 = Black</p>
MBCC-412	3.66 m (12 ft)			
MBCC-430	9.14 m (30 ft)			



## Retroreflective Targets

Banner offers a wide selection of high-quality retroreflective targets. See [www.bannerengineering.com](http://www.bannerengineering.com) for complete information.



**NOTE:** Polarized sensors require corner cube type retroreflective targets. Non-polarized sensors may use any retroreflective target.

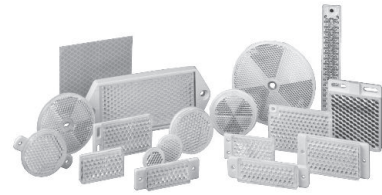

## Brackets

### SMB30C

- 30 mm split clamp, black PBT bracket
- Stainless steel mounting hardware included
- Mounting hole for 30 mm sensor

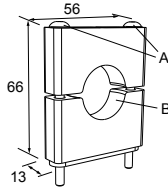

**Hole center spacing:** A=  $\varnothing$  45  
**Hole size:** B=  $\varnothing$  27.2

### SMB30MM

- 12-ga. stainless steel bracket with curved mounting slots for versatile orientation
- Clearance for M6 (1/4 in) hardware
- Mounting hole for 30 mm sensor

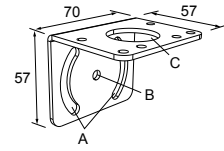

**Hole center spacing:** A = 51, A to B = 25.4  
**Hole size:** A = 42.6 x 7, B =  $\varnothing$  6.4, C =  $\varnothing$  30.1

### SMB30SC

- Swivel bracket with 30 mm mounting hole for sensor
- Black reinforced thermoplastic polyester
- Stainless steel mounting and swivel locking hardware included

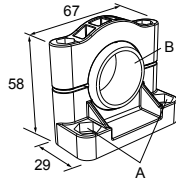

**Hole center spacing:** A=  $\varnothing$  50.8  
**Hole size:** A=  $\varnothing$  7.0, B=  $\varnothing$  30.0

## Output Timing Logic and Signal Strength Display Modules

Q45 sensors easily accept the addition of output timing logic and signal strength display functions. Display modules have a seven-element display that gives a more precise indication of excess gain than does the AID™ system LED that is standard on Q45 sensors. The modules listed below may be used with all Q45BB6 sensors. Refer to the module's datasheet for more information.

Models	Logic and/ or Display Function
45LM58	Programmable output timing logic
45LM58D	Programmable output timing logic plus signal strength display
45LMD	Signal strength display only (no timing function)

## Banner Engineering Corp. Limited Warranty

---

Banner Engineering Corp. warrants its products to be free from defects in material and workmanship for one year following the date of shipment. Banner Engineering Corp. will repair or replace, free of charge, any product of its manufacture which, at the time it is returned to the factory, is found to have been defective during the warranty period. This warranty does not cover damage or liability for misuse, abuse, or the improper application or installation of the Banner product.

**THIS LIMITED WARRANTY IS EXCLUSIVE AND IN LIEU OF ALL OTHER WARRANTIES WHETHER EXPRESS OR IMPLIED (INCLUDING, WITHOUT LIMITATION, ANY WARRANTY OF MERCHANTABILITY OR FITNESS FOR A PARTICULAR PURPOSE), AND WHETHER ARISING UNDER COURSE OF PERFORMANCE, COURSE OF DEALING OR TRADE USAGE.**

This Warranty is exclusive and limited to repair or, at the discretion of Banner Engineering Corp., replacement. **IN NO EVENT SHALL BANNER ENGINEERING CORP. BE LIABLE TO BUYER OR ANY OTHER PERSON OR ENTITY FOR ANY EXTRA COSTS, EXPENSES, LOSSES, LOSS OF PROFITS, OR ANY INCIDENTAL, CONSEQUENTIAL OR SPECIAL DAMAGES RESULTING FROM ANY PRODUCT DEFECT OR FROM THE USE OR INABILITY TO USE THE PRODUCT, WHETHER ARISING IN CONTRACT OR WARRANTY, STATUTE, TORT, STRICT LIABILITY, NEGLIGENCE, OR OTHERWISE.**

Banner Engineering Corp. reserves the right to change, modify or improve the design of the product without assuming any obligations or liabilities relating to any product previously manufactured by Banner Engineering Corp. Any misuse, abuse, or improper application or installation of this product or use of the product for personal protection applications when the product is identified as not intended for such purposes will void the product warranty. Any modifications to this product without prior express approval by Banner Engineering Corp will void the product warranties. All specifications published in this document are subject to change; Banner reserves the right to modify product specifications or update documentation at any time. Specifications and product information in English supersede that which is provided in any other language. For the most recent version of any documentation, refer to: [www.bannerengineering.com](http://www.bannerengineering.com).