

Q45BB6LL Laser Diode Retroreflective Sensors

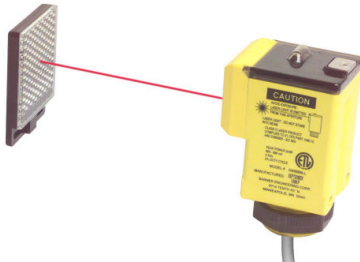

Datasheet

Very-Long-Range Retroreflective Sensors for 10 V to 30 V dc



- High power and small effective beam for retroreflective sensing applications
- Class II laser diode light source; operates from 10 V to 30 V dc
- 40 m (130 ft) range for polarized models and 70 m (225 ft) range for non-polarized models, using supplied BRT-2x2 target
- Bipolar NPN (sinking) and PNP (sourcing) solid-state outputs, switchable light and dark operate; 250 mA maximum load
- Top mounted Power, Signal (AID™ System), and Output indicator LEDs
- Optional plug-in Pulse or Delay timing logic and display modules
- Designed to withstand 1200 psi washdown; exceeds its NEMA 6P and IEC IP67 rating

U.S. Patent(s) issued or pending



WARNING: Not To Be Used for Personnel Protection

Never use this device as a sensing device for personnel protection. Doing so could lead to serious injury or death. This device does not include the self-checking redundant circuitry necessary to allow its use in personnel safety applications. A sensor failure or malfunction can cause either an energized or de-energized sensor output condition.

Models

Non-Polarized Models				
Model	Cable ¹	Range	Beam Color	Sensing Mode
Q45BB6LL	5-wire 2 m (6.5 ft)	0.3 to 70 m (1 ft to 225 ft) w/BRT-2x2 (included)	Visible red, 655 nm	RETRO
Q45BB6LLQ	5-Pin Mini-style QD			
Q45BB6LLQ6	5-Pin Euro-style QD			
Polarized Models				
Model	Cable ¹	Range	Beam Color	Sensing Mode
Q45BB6LLP	5-wire 2 m (6.5 ft)	0.6 to 40 m (2 ft to 130 ft) w/BRT-2x2 (included)	Visible red, 655 nm	POLAR RETRO
Q45BB6LLPQ	5-Pin Mini-style QD			
Q45BB6LLPQ6	5-Pin Euro-style QD			

¹

- To order the 9 m (30 ft) cable models, add the suffix "W/30" to the cabled model number.
- Models with a quick disconnect (QD) connector require a mating cable.



Overview

Status indicator LEDs for Power, Signal and Output are clearly visible beneath a raised dome in the sensor's transparent o-ring-sealed polycarbonate cover. The Power indicator lights whenever power is applied to the sensor. The Signal LED lights whenever the sensor sees its modulated light source, and pulses at a rate proportional to the strength of the received light signal; this is the AID™ Alignment Indicating Device. The Output indicator lights whenever the sensor's output is conducting. This indicator is especially useful when a timing logic module is used and Signal and Output conditions are not concurrent.

Also located beneath the sensor's o-ring-sealed cover are controls for light/dark operate selection and Sensitivity (gain) adjustment.

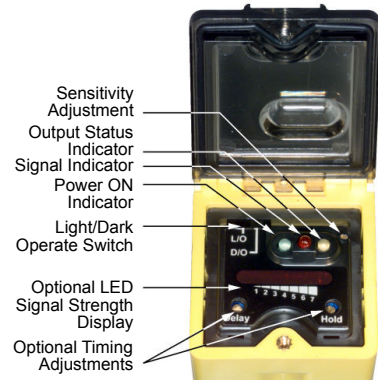

CAUTION: Never stare directly into the sensor lens. Laser light can damage your eyes. Avoid placing any mirror-like object in the beam. Never use a mirror as a retroreflective target.



CAUTION: Do Not Disassemble for Repair

This device contains no user-serviceable components. Do not attempt to disassemble for repair. Use of controls or adjustments or performance of procedures other than those specified herein may result in hazardous radiation exposure. A defective unit must be returned to the manufacturer.

Device Setup

Alignment

Conventional retroreflective photoelectric sensors are extremely easy to align. Beam angles are wide, and retro targets are forgiving to angle of incidence of the light beam. The beam of the Q45 laser sensor is very narrow, compared with the beam of most retro sensors. As [Table 1](#) on page 2 indicates, the effect of angular misalignment can be dramatic. Alignment is critical because the beam may miss the retroreflective target unless the retro target is large.

For example, with one BRT-2x2 mounted at a distance of 6 m (20 ft) from the sensor, one degree of angular misalignment will cause the center of the laser beam to miss the center of the target by 4 inches (i.e., the beam will miss the edge of the reflector by almost 3 inches).

Table 1: Beam Displacement per Degree of Misalignment

Sensor-to-Target Distance (X)	Beam Displacement (Y) for 1
1.5 m (5 feet)	25 mm (1 inches)
3 m (10 feet)	50 mm (2 inches)
3 m (10 feet)	100 mm (4 inches)
15 m (50 feet)	250 mm (10 inches)
30 m (100 feet)	500 mm (20 inches)
45 m (150 feet)	750 mm (30 inches)
60 m (200 feet)	1000 mm (40 inches)

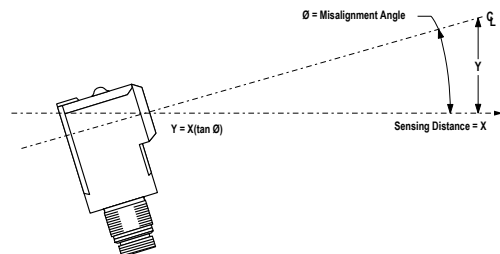

Alignment Tip

When using a small retroreflective target at medium or long range, temporarily attach (or suspend) a strip of retroreflective tape (e.g., BRT-THG-2) along a line which intersects the actual target. The visible red laser beam is easily seen in normal room lighting. Sight along the beam toward the target (from behind the sensor). Move the sensor to scan the laser beam back and forth across the retro tape strip. Use the tape strip to guide the beam onto the target.

Consider the use of Banner sensor mounting bracket SMB30SC. This swivel bracket can simplify multiple-axis alignment. Alignment is complete when the visible image is centered on the retro target. The perpendicularity of the laser beam to the face of the retro target is forgiving, just as it is with a conventional retroreflective sensor.

Effective Beam Size

Unlike conventional retroreflective sensors, the retroreflective laser has the ability to sense relatively small profiles. [Table 2](#) on page 3 indicates the diameter of the smallest opaque rod which will reliably break the laser beam at several sensor-to-object distances. These figures assume an excess gain of about 10 times. Flooding effects are possible when the gain is much higher. This means that sensor gain may have to be reduced in some situations in order to reliably detect these minimum object sizes.

Note that the shape of the beam is elliptical. The minimum object sizes listed assume passage of the rod across the major diameter of the ellipse (worst case). It may be possible to detect objects smaller than the sizes listed if the direction in which the objects pass through the beam can be controlled.

Table 2: Minimum Object Detection Size vs. Distance from Sensor

Distance from Sensor to Object	Minimum Object Detection Size
0.3 m (1 feet)	2.5 mm (0.10 inches)
1.5 m (5 feet)	3.0 mm (0.12 inches)
3 m (10 feet)	4.5 mm (0.18 inches)
15 m (50 feet)	19 mm (0.75 inches)
30 m (100 feet)	25 mm (1.0 inches)

Wiring Diagrams

Cabled Models

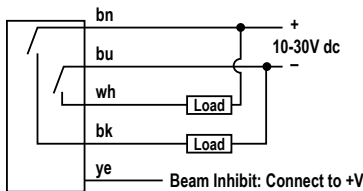

Mini- or Euro-Style Quick-Disconnect Models

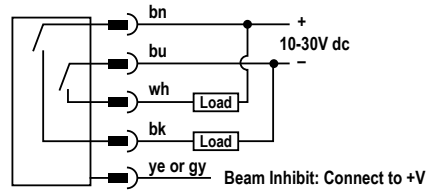

Specifications

Supply Voltage and Current

10 V to 30 V dc (10% maximum ripple), at less than 50 mA (exclusive of load)

Supply Protection Circuitry

Protected against reverse polarity and transient voltages

Output Configuration

Bipolar: one current sourcing (PNP) and one current sinking (NPN) open-collector transistor

Output Rating

250 mA maximum each output up to 50° C, derated to 150 mA at 70° C (derate 5 mA/°C)

Off-state leakage current: less than 1 microamp

Output saturation voltage (both outputs): less than 1 volt at 10 mA and less than 2 volts at 250 mA

Output Protection Circuitry

Protected against false pulse on power-up and continuous overload or short circuit of outputs

Output Response Time

Less than 2 milliseconds

1 second delay on power-up; outputs do not conduct during this time.

Repeatability

0.5 milliseconds; response time and repeatability specifications are independent of signal strength

Indicators

Indicator LEDs are visible beneath a raised transparent polycarbonate dome on top of the sensor.

Power (green) LED: lights whenever 10 V to 30 V dc power is applied, and flashes to indicate output overload or output short circuit. A steady green LED also indicates that laser light is being emitted.

Signal (red) AID™ system LED: lights whenever the sensor sees its modulated light source, and pulses at a rate proportional to the strength of the received light signal

Load (amber) LED: lights whenever an output is conducting

Optional 7-element LED: signal strength display module

Adjustments

Beneath sensor's transparent cover: Light/Dark Operate select switch and multi-turn Sensitivity control on top of sensor allow precise sensitivity setting (turn clockwise to increase gain). Optional logic and logic/display modules have adjustable timing functions.

Construction

Molded thermoplastic polyester housing, o-ring sealed transparent polycarbonate top cover, molded acrylic lenses, and stainless steel hardware. Q45 sensors are designed to withstand 1200 psi washdown. The base of cabled models has a 1/2" NPS integral internal conduit thread.

Environmental Rating

NEMA 6P, IEC IP67

Laser Classification

Class II laser product. US Safety Standards 21 CFR 1040.10 and 1040.11; European Standards EN 60825 and IEC 60825

Connections

PVC-jacketed 2 m (6.5 ft) or 9 m (30 ft) cables, or 5-pin Mini-style ("Q" suffix models) or 5-pin Euro-style ("Q6" suffix models) quick disconnect (QD) fitting are available. QD cables are ordered separately.

Operating Conditions

-10° to +40° C (+14° to 104° F)

90% at +50 °C maximum relative humidity (non-condensing)

Application Notes

Optional logic timing modules are available

Certifications

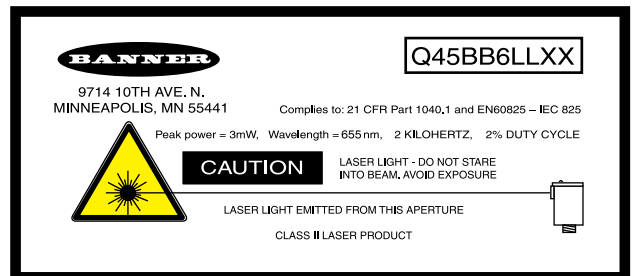

Dimensions

Cabled Models

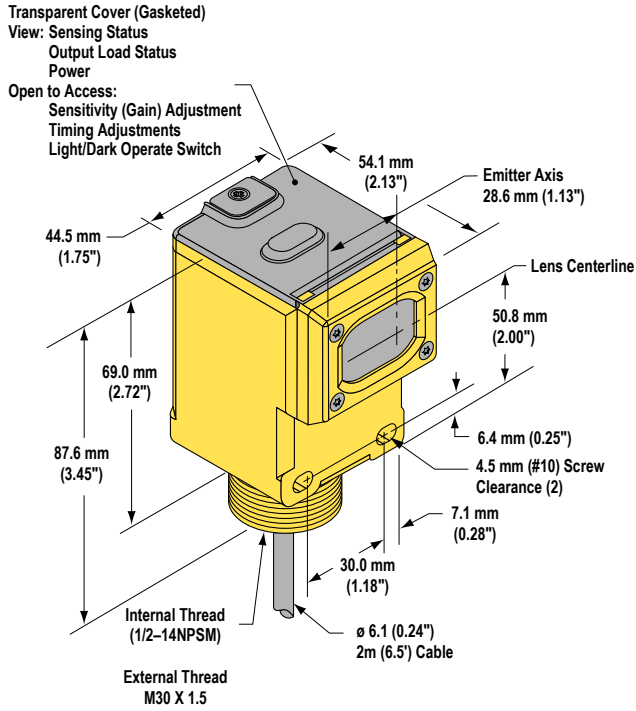

5-Pin Mini-Style Quick-Disconnect Models

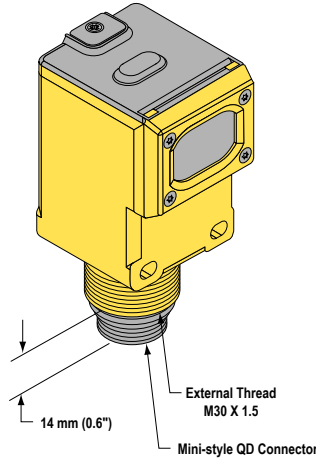

5-Pin Euro-Style Quick-Disconnect Models

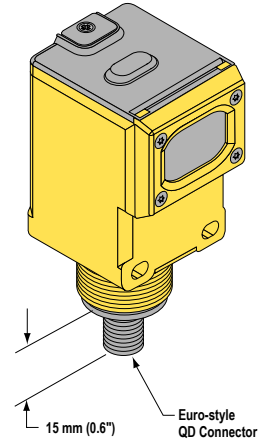

Excess Gain Curves

Non-Polarized Models

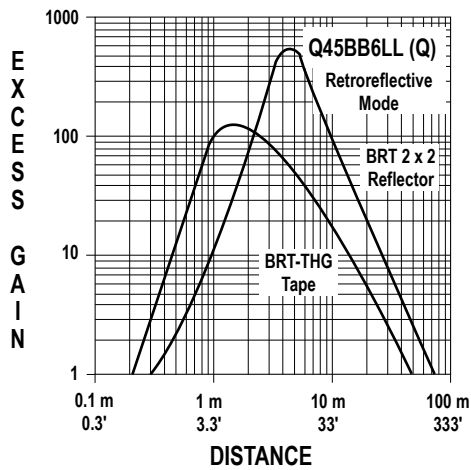

Polarized Models

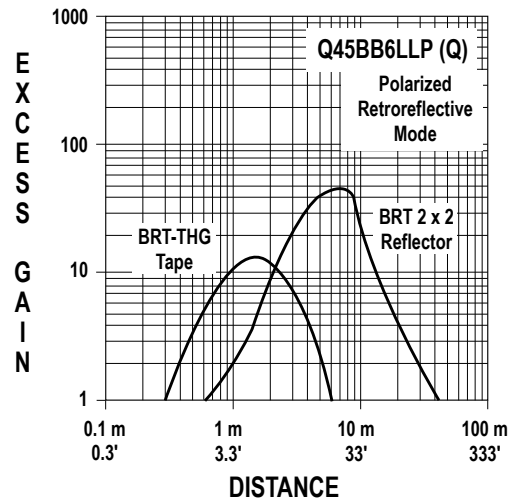

Accessories

Quick-Disconnect (QD) Cables

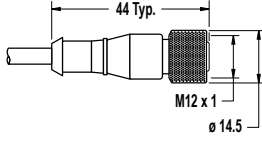
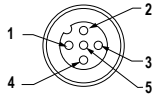
5-Pin Threaded M12/ Euro-Style Cordsets—Single Ended				
Model	Length	Style	Dimensions	Pinout (Female)
MQDC1-501.5	0.50 m (1.5 ft)	Straight		 1 = Brown 2 = White 3 = Blue 4 = Black 5 = Gray
MQDC1-506	1.83 m (6 ft)			
MQDC1-515	4.57 m (15 ft)			
MQDC1-530	9.14 m (30 ft)			

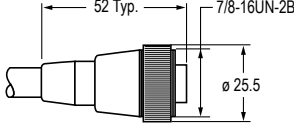
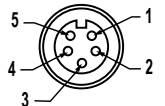
5-Pin Mini-Style Cordsets				
Model	Length	Style	Dimensions	Pinout (Female)
MBCC-506	1.83 m (6 ft)	Straight		 1 = Black 2 = Blue 3 = Yellow 4 = Brown 5 = White
MBCC-512	3.66 m (12 ft)			
MBCC-530	9.14 m (30 ft)			

Retroreflective Targets

Banner offers a wide selection of high-quality retroreflective targets. See the Accessories section of your current Banner Photoelectric Sensors catalog for complete information.



NOTE: Polarized sensors require corner cube type retroreflective targets only. Non-polarized sensors may use any retroreflective target.

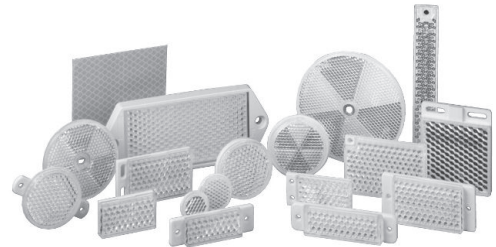

Output Timing Logic and Signal Strength Display Modules

Q45 sensors easily accept the addition of output timing logic and signal strength display functions. Display modules have a seven-element display that gives a more precise indication of excess gain than does the AID™ system LED that is standard on Q45 sensors. The modules listed below may be used with all Q45BB6LL sensors. Refer to the module's datasheet for more information.

Models	Logic and/ or Display Function
45LM58	Programmable output timing logic
45LM58D	Programmable output timing logic plus signal strength display
45LMD	Signal strength display only (no timing function)

Mounting Brackets

SMB30A

- Right-angle bracket with curved slot for versatile orientation
- Clearance for M6 (1/4 in) hardware
- Mounting hole for 30 mm sensor
- 12-ga. stainless steel

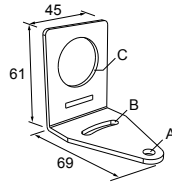

Hole center spacing: A to B= 40

Hole size: A= \varnothing 6.3, B= 27.1 x 6.3, C= \varnothing 30.5

SMB30UR

- 2-piece universal swivel bracket for limit-switch style sensors
- 300 series stainless steel
- Stainless steel swivel locking hardware included

Hole center spacing: A to B= 31.8, B to C= 19.0, A to C= 50.8, D= 50.8

Hole size: C= 6.9x32, D= 73.0x6.9

SMB30MM

- 12-ga. stainless steel bracket with curved mounting slots for versatile orientation
- Clearance for M6 (1/4 in) hardware
- Mounting hole for 30 mm sensor

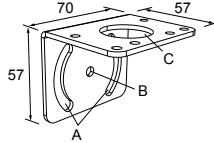

Hole center spacing: A = 51, A to B = 25.4

Hole size: A = 42.6 x 7, B = \varnothing 6.4, C = \varnothing 30.1

SMBAMS30P

- Flat SMBAMS series bracket
- 30 mm hole for mounting sensors
- Articulation slots for 90°+ rotation
- 12-ga. 300 series stainless steel

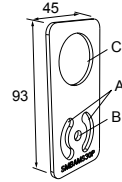

Hole center spacing: A= 26.0, A to B= 13.0

Hole size: A= 26.8 x 7.0, B= \varnothing 6.5, C= \varnothing 31.0

SMB30Q

- Right-angle flanged mounting bracket with curved slot for versatile orientation
- 12-ga. stainless steel
- Mounting hole for 30 mm sensor

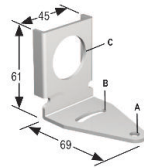

Hole center spacing: A to B= 40

Hole size: A= \varnothing 6.3, B= \varnothing 27.1 x 6.3, C= \varnothing 30.7

SMBAMS30RA

- Right-angle SMBAMS series bracket
- 30 mm hole for mounting sensors
- Articulation slots for 90°+ rotation
- 12-ga. (2.6 mm) cold-rolled steel

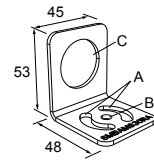

Hole center spacing: A= 26.0, A to B= 13.0

Hole size: A= 26.8 x 7.0, B= \varnothing 6.5, C= \varnothing 31.0

SMB30SC

- Swivel bracket with 30 mm mounting hole for sensor
- Black reinforced thermoplastic polyester
- Stainless steel mounting and swivel locking hardware included

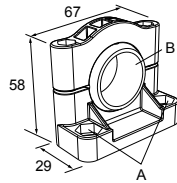

Hole center spacing: A= \varnothing 50.8

Hole size: A= \varnothing 7.0, B= \varnothing 30.0

Banner Engineering Corp. Limited Warranty

Banner Engineering Corp. warrants its products to be free from defects in material and workmanship for one year following the date of shipment. Banner Engineering Corp. will repair or replace, free of charge, any product of its manufacture which, at the time it is returned to the factory, is found to have been defective during the warranty period. This warranty does not cover damage or liability for misuse, abuse, or the improper application or installation of the Banner product.

THIS LIMITED WARRANTY IS EXCLUSIVE AND IN LIEU OF ALL OTHER WARRANTIES WHETHER EXPRESS OR IMPLIED (INCLUDING, WITHOUT LIMITATION, ANY WARRANTY OF MERCHANTABILITY OR FITNESS FOR A PARTICULAR PURPOSE), AND WHETHER ARISING UNDER COURSE OF PERFORMANCE, COURSE OF DEALING OR TRADE USAGE.

This Warranty is exclusive and limited to repair or, at the discretion of Banner Engineering Corp., replacement. **IN NO EVENT SHALL BANNER ENGINEERING CORP. BE LIABLE TO BUYER OR ANY OTHER PERSON OR ENTITY FOR ANY EXTRA COSTS, EXPENSES, LOSSES, LOSS OF PROFITS, OR ANY INCIDENTAL, CONSEQUENTIAL OR SPECIAL DAMAGES RESULTING FROM ANY PRODUCT DEFECT OR FROM THE USE OR INABILITY TO USE THE PRODUCT, WHETHER ARISING IN CONTRACT OR WARRANTY, STATUTE, TORT, STRICT LIABILITY, NEGLIGENCE, OR OTHERWISE.**

Banner Engineering Corp. reserves the right to change, modify or improve the design of the product without assuming any obligations or liabilities relating to any product previously manufactured by Banner Engineering Corp.

Copyright Notice

Any misuse, abuse, or improper application or installation of this product or use of the product for personal protection applications when the product is identified as not intended for such purposes will void the product warranty. Any modifications to this product without prior express approval by Banner Engineering Corp will void the product warranties. All specifications published in this document are subject to change; Banner reserves the right to modify product specifications or update documentation at any time. For the most recent version of any documentation, refer to: www.bannerengineering.com. © Banner Engineering Corp. All rights reserved.

