

Datasheet

Universal Voltage Photoelectric Sensors with Electromechanical Relay Output



- Advanced one-piece photoelectric sensors with outstanding optical performance and extremely rugged design
- Universal supply voltage: 12 to 250 V dc or 24 to 250 V ac
- Electromechanical relay for economical, high-capacity switching and immunity to electrical noise
- Multiple sensing modes available: opposed, diffuse, retroreflective, and convergent, plus glass and plastic fiber optic models
- Selectable light/dark operate
- Versatile plug-in modules available for output timing logic and/or signal strength display
- Highly visible Power, Signal (AID™ System ¹), and Output indicator LEDs
- Choice of prewired 2 m (6.5 ft) or 9 m (30 ft) unterminated cable or Mini-style quick-disconnect fitting
- Versatile mounting options
- Designed to withstand 1200 psi washdown; exceeds its NEMA 6P and IEC IP67 rating



WARNING: Not To Be Used for Personnel Protection

Never use this device as a sensing device for personnel protection. Doing so could lead to serious injury or death. This device does not include the self-checking redundant circuitry necessary to allow its use in personnel safety applications. A sensor failure or malfunction can cause either an energized or de-energized sensor output condition.

Models

To order the 9 m (30 ft) cable models, add the suffix "W/30" to the cabled model number. For example: Q453EW/30.

Models with a quick disconnect (QD) connector require a mating cable.

Opposed-Mode Emitter (E) and Receiver (R) Models

Because of their extremely high excess gain, these opposed-mode sensors are an excellent option for sensing in contaminated or dirty areas, and are also the best choice for long-range sensing.

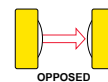

Infrared, 880 nm

Models	Cable	Range	Supply Voltage	Output Type
Q453E Emitter	2-wire 2 m (6.5 ft) cable	60 m (200 ft)	Universal 12 to 250 V dc or 24 to 250 V ac	SPDT Electro-mechanical relay
Q45VR3R Receiver	5-wire 2 m (6.5 ft) cable			
Q453EQ Emitter	3-Pin Mini-style QD			
Q45VR3RQ Receiver	5-Pin Mini-style QD			

Retroreflective-Mode Models

The visible red sensing beam of these sensors makes them very easy to align. Model Q45VR3LP polarizes the emitted light and filters out unwanted reflections, making sensing possible in applications otherwise considered unsuited to retroreflective sensing. Specified using the model BRT-3 3-inch reflector (go to www.bannerengineering.com for additional information).

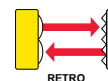

Visible red, 680 nm
(non-polarized)



Visible red, 680 nm
(polarized)

¹ U.S. Patent no. 4356393



Non-Polarized				
Models	Range	Cable	Supply Voltage	Output Type
Q45VR3LV	0.08 to 9 m (3 in to 30 ft)	5-wire 2 m (6.5 ft) cable	Universal 12 to 250 V dc or 24 to 250 V ac	SPDT Electro-mechanical relay
Q45VR3LVQ		5-Pin Mini-style QD		

Polarized				
Models	Range	Cable	Supply Voltage	Output Type
Q45VR3LP	0.15 to 6 m (6 in to 20 ft)	5-wire 2 m (6.5 ft) cable	Universal 12 to 250 V dc or 24 to 250 V ac	SPDT Electro-mechanical relay
Q45VR3LPQ		5-Pin Mini-style QD		

Diffuse-Mode Models

These diffuse-mode models detect objects by sensing the reflection of their own emitted light. Ideal for use when the reflectivity and profile of the object to be sensed are sufficient to return a large percentage of emitted light back to the sensor. Model Q45VR3DX is the first choice for diffuse-mode applications when there are no background objects to falsely return light.

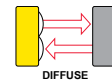

Infrared, 880 nm

Short Range				
Models	Range	Cable	Supply Voltage	Output Type
Q45VR3D	45 cm (18 inches)	5-wire 2 m (6.5 ft) cable	Universal 12 to 250 V dc or 24 to 250 V ac	SPDT Electro-mechanical relay
Q45VR3DQ		5-Pin Mini-style QD		

Long Range				
Models	Range	Cable	Supply Voltage	Output Type
Q45VR3DL	1.8 m (6 ft)	5-wire 2 m (6.5 ft) cable	Universal 12 to 250 V dc or 24 to 250 V ac	SPDT Electro-mechanical relay
Q45VR3DLQ		5-Pin Mini-style QD		

High Power				
Models	Range	Cable	Supply Voltage	Output Type
Q45VR3DX	3 m (10 ft)	5-wire 2 m (6.5 ft) cable	Universal 12 to 250 V dc or 24 to 250 V ac	SPDT Electro-mechanical relay
Q45VR3DXQ		5-Pin Mini-style QD		

Convergent-Mode Models

These sensors are ideal for reflective sensing of very small parts or profiles, and can accurately sense the position of parts approaching from the side. Ignores all but highly reflective objects that are outside the sensing range.

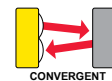

Visible red, 680 nm

Models	Focus	Cable	Supply Voltage	Output Type
Q45VR3CV	38 mm (1.5 in)	5-wire 2 m (6.5 ft) cable	Universal 12 to 250 V dc or 24 to 250 V ac	SPDT Electro-mechanical relay
Q45VR3CVQ	Spot Size at Focus: 1.3 mm (0.05 in)			
Q45VR3CV4	100 mm (4 in)	5-wire 2 m (6.5 ft) cable	Universal 12 to 250 V dc or 24 to 250 V ac	SPDT Electro-mechanical relay
Q45VR3CV4Q	Spot Size at Focus: 1.5 mm (0.06 in)			

Glass Fiber Optic Models

These models are an excellent choice for glass fiber optic applications where faster sensor response is not important. Their high excess gain means that opposed individual fibers can operate reliably in many very hostile environments. Also, special miniature bifurcated fiber optic assemblies with bundle sizes as small as 0.5 mm (.020 in) diameter may be used successfully for diffuse-mode sensing when using sensor model Q45VR3F(Q). For more information on compatible glass fiber optics, go to www.bannerengineering.com.

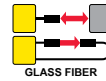

Infrared, 880 nm and Visible red, 650 nm

Infrared, 880 nm				
Models	Range	Cable	Supply Voltage	Output Type
Q45VR3F	Range varies by sensing mode and fiber optics used.	5-wire 2 m (6.5 ft) cable	Universal 12 to 250 V dc or 24 to 250 V ac	SPDT Electro-mechanical relay
Q45VR3FQ		5-Pin Mini-style QD		

Visible Red, 650 nm				
Models	Range	Cable	Supply Voltage	Output Type
Q45VR3FV	Range varies by sensing mode and fiber optics used.	5-wire 2 m (6.5 ft) cable	Universal 12 to 250 V dc or 24 to 250 V ac	SPDT Electro-mechanical relay
Q45VR3FVQ		5-Pin Mini-style QD		

Plastic Fiber Optic Models

Lower in cost than glass fiber optics, plastic fiber optics are ideal for use in situations where environmental conditions allow (for example, low levels of acids, alkalis, and solvents). Most are easily cut to length in the field, and are available in a variety of sensing end styles. For more information on compatible plastic fiber optics, go to www.bannerengineering.com.

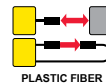

Visible red, 660 nm

Models	Range	Cable	Supply Voltage	Output Type
Q45VR3FP	Range varies by sensing mode and fiber optics used.	5-wire 2 m (6.5 ft) cable	Universal 12 to 250 V dc or 24 to 250 V ac	SPDT Electro-mechanical relay
Q45VR3FPQ		5-Pin Mini-style QD		

Overview

Status indicator LEDs for power, signal, and output are clearly visible beneath a raised dome in the sensor's transparent o-ring-sealed polycarbonate cover. Also located beneath the sensor's o-ring-sealed cover are controls for light/dark operate selection and the sensitivity adjustment.

- The power indicator (green) lights when power is applied to the sensor.
- The signal indicator (red) lights when the sensor sees its modulated light source and pulses at a rate proportional to the strength of the received light signal; this is the AID™ Alignment Indicating Device².
- The output indicator (amber) lights when the sensor's output is conducting. This indicator is especially useful when a timing logic module is used and signal and output conditions are not concurrent.



1. Sensitivity adjustment
2. LEDs
 - Green LED: Power on indicator
 - Red LED: Signal indicator
 - Amber LED: Output status indicator
3. Optional LED signal strength display
4. Optional timing adjustment
5. Optional timing adjustment
6. Light/dark operate switch

² USpatent no. 4356393

Wiring Diagrams

Q45VR3 Sensors with Attached Cable

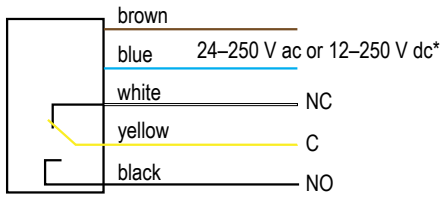

Q45VR3 Sensors with Quick-Disconnect 5-Pin M ini-Style (model suffix Q)

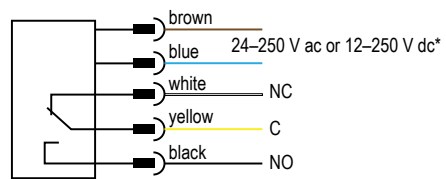

Q453E Emitters with Attached Cable

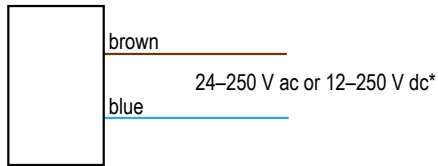

Q453EQ Emitters with Quick-Disconnect 3-Pin M ini-Style

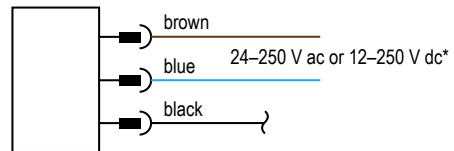

*Connection of dc power is without regard to polarity.

Specifications

Supply Voltage and Current

Universal voltage: 24 to 250 V ac, 50/60 Hz or 12 to 250 V dc (1.5 watts maximum)

Supply Protection Circuitry

Protected against transient voltages
DC hookup is without regard to polarity.

Output Configuration

SPDT (Single-Pole, Double-Throw) electromechanical relay output. All models except emitters.

Output Rating

Max. switching power (resistive load): 1250 VA, 150 W
Max. switching voltage (resistive load): 250 V ac, 125 V dc
Max. switching current (resistive load): 5 A @ 250 V ac, 5A @ 30 V dc derated to 200 mA @ 125 V dc
Min. voltage and current: 5 V dc, 10 mA
Mechanical life of relay: 50,000,000 operations
Electrical life of relay at full resistive load: 100,000 operations

Output Protection Circuitry

Protected against false pulse on power-up

Output Response Time

15 milliseconds ON and OFF



Note: 100 millisecond delay on power-up. Relay is de-energized during this time.

Required Overcurrent Protection



WARNING: Electrical connections must be made by qualified personnel in accordance with local and national electrical codes and regulations.

Overcurrent protection is required to be provided by end product application per the supplied table.

Overcurrent protection may be provided with external fusing or via Current Limiting, Class 2 Power Supply.

Supply wiring leads < 24 AWG shall not be spliced.

For additional product support, go to www.bannerengineering.com.

Supply Wiring (AWG)	Required Overcurrent Protection (Amps)
20	5.0
22	3.0
24	2.0
26	1.0
28	0.8
30	0.5

Repeatability

Opposed mode: 0.25 milliseconds

All other sensing modes: 0.5 milliseconds

Response time and repeatability specifications are independent of signal strength

Adjustments

Light/Dark Operate select switch; and multi-turn Sensitivity control on top of sensor beneath a transparent o-ring-sealed cover, allows precise sensitivity setting (turn clockwise to increase gain). Optional logic and logic/display modules have adjustable timing functions.

Indicators

Indicator LEDs are clearly visible beneath a raised transparent Lexan® dome on top of the sensor.

Power (green) LED lights whenever 24 to 250 V ac, or 12 to 250 V dc power is applied

Signal (red) AID™ System LED lights whenever the sensor sees its modulated light source, and pulses at a rate proportional to the strength of the received light signal

Load (amber) LED lights whenever the output relay is energized

Optional 7-element LED signal strength display module

Construction

Molded reinforced thermoplastic polyester housing, o-ring-sealed transparent Lexan® cover, molded acrylic lenses, and stainless steel hardware. Q45s are designed to withstand 1200 psi washdown. The base of cabled models has a 1/2-inch NPS integral internal conduit thread.

Environmental Rating

NEMA 6P, IEC IP67

Connections

PVC-jacketed 2 m (6.5 ft) or 9 m (30 ft) unterminated cables, or Mini-style quick-disconnect (QD) fittings are available ("Q" - suffix models). QD cables are ordered separately.

Operating Conditions

Temperature: -25 °C to +55 °C (-13 °F to +131 °F)

90% at +50 °C maximum relative humidity (non-condensing)

Application Notes

Transient suppression is recommended for contacts switching inductive loads. Optional output timing modules are available. See [Output Timing Logic and Signal Strength Display Modules](#) on page 10 for more information.

Certifications



[®] Lexan® is a registered trademark of General Electric Co.

Dimensions

Opposed, Retro, and Diffuse Sensing Modes (Model Suffix E, R, D, DL, DX, LP, and LV)

Cabled Models

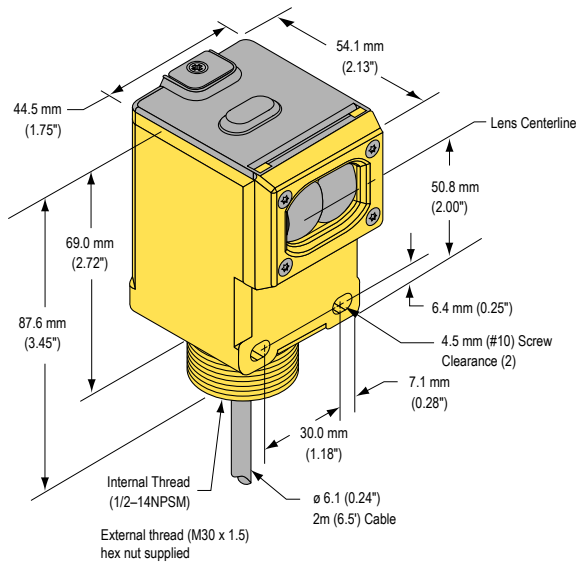

Quick-Disconnect Models

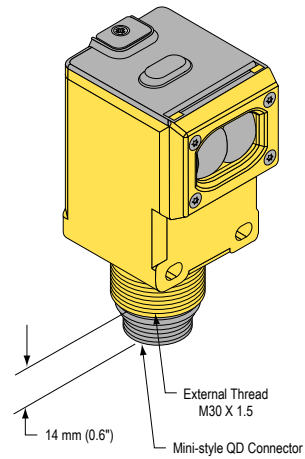

Convergent Sensor Models (CV and CV4)

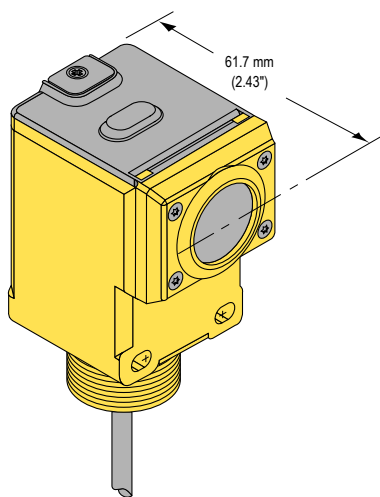

Glass Fiber Optic Models (F and FV)

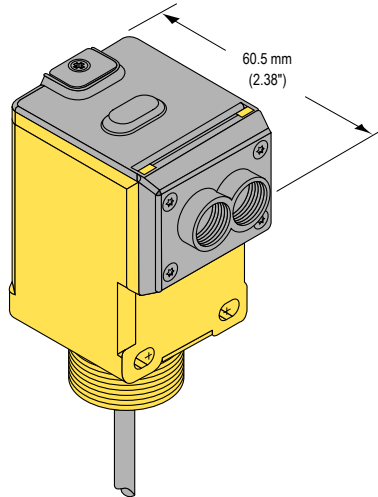

Plastic Fiber Optic Models (FP)

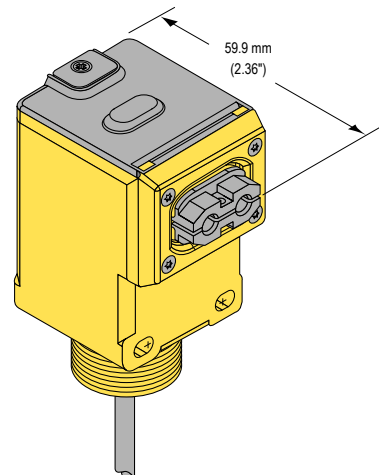

Performance Curves

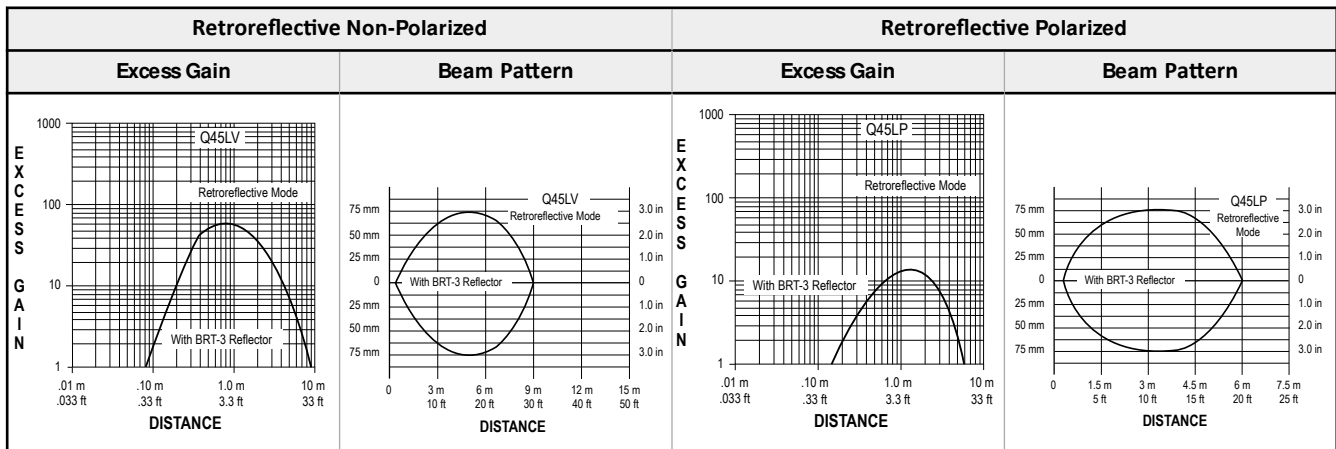
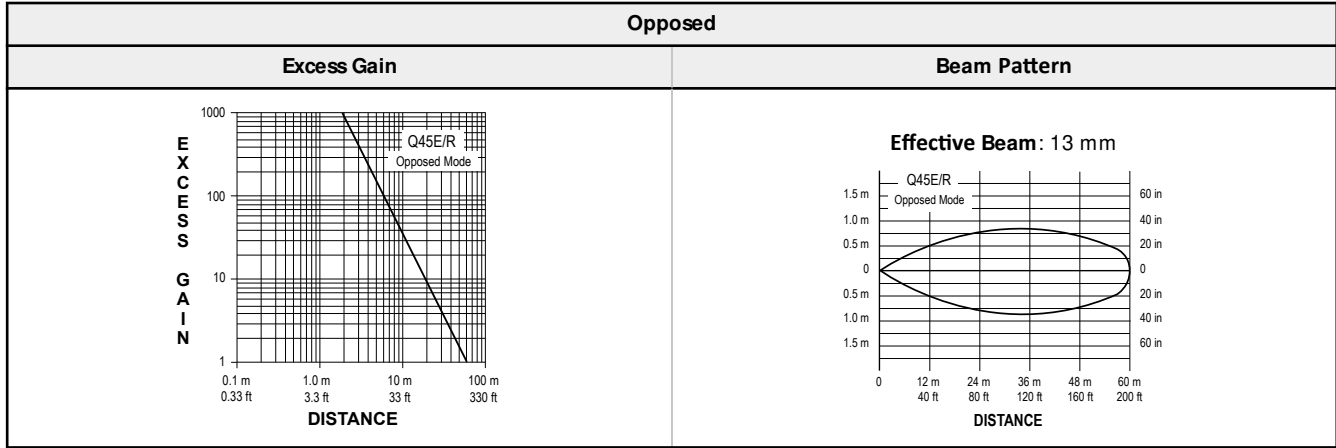

Diffuse-mode performance curves are based on a 90% reflectance white test card.

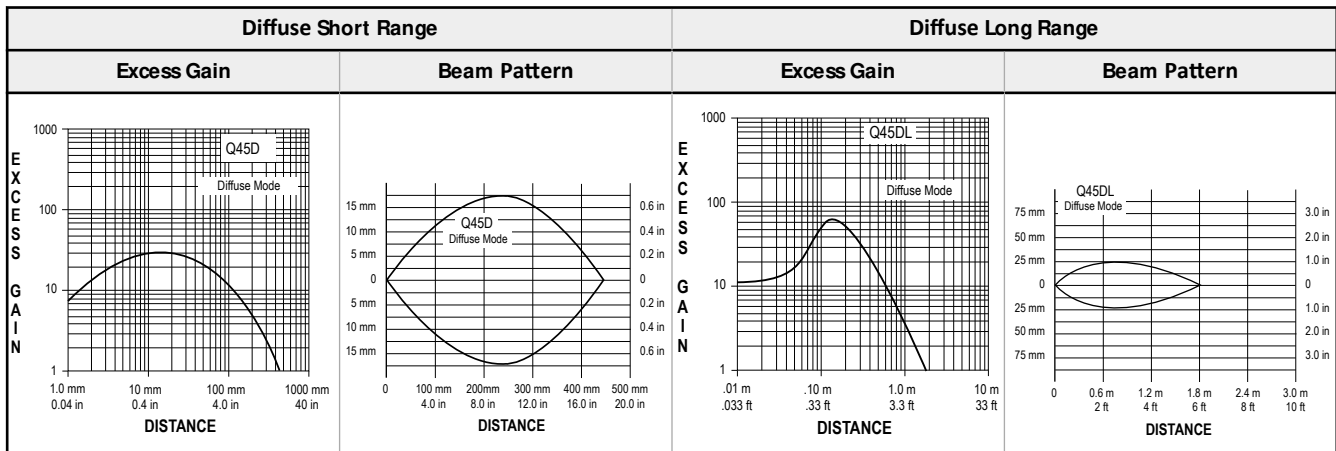

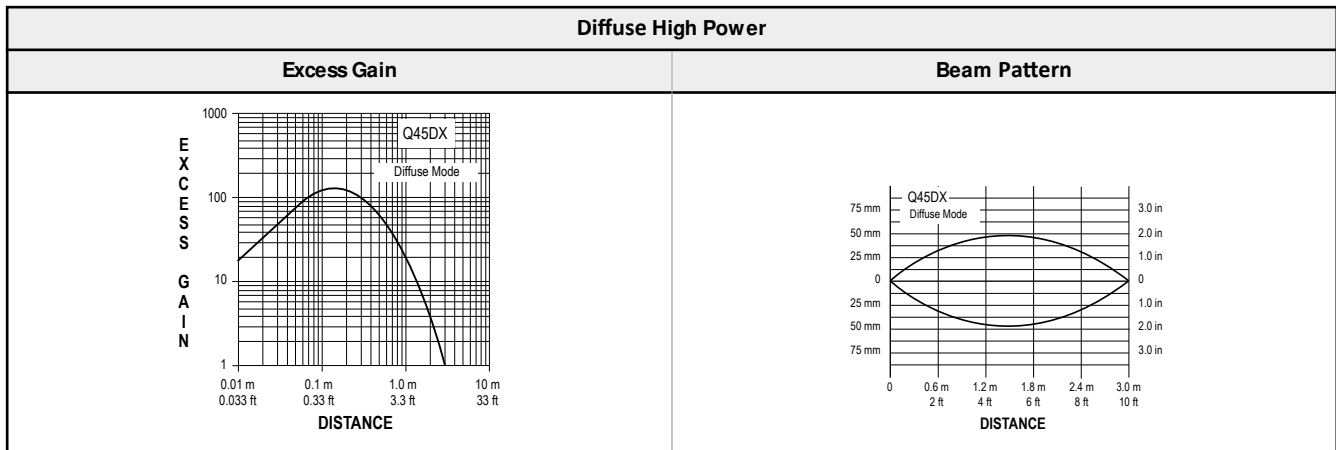

Convergent mode performance curves are based on a 90% reflectance white test card.

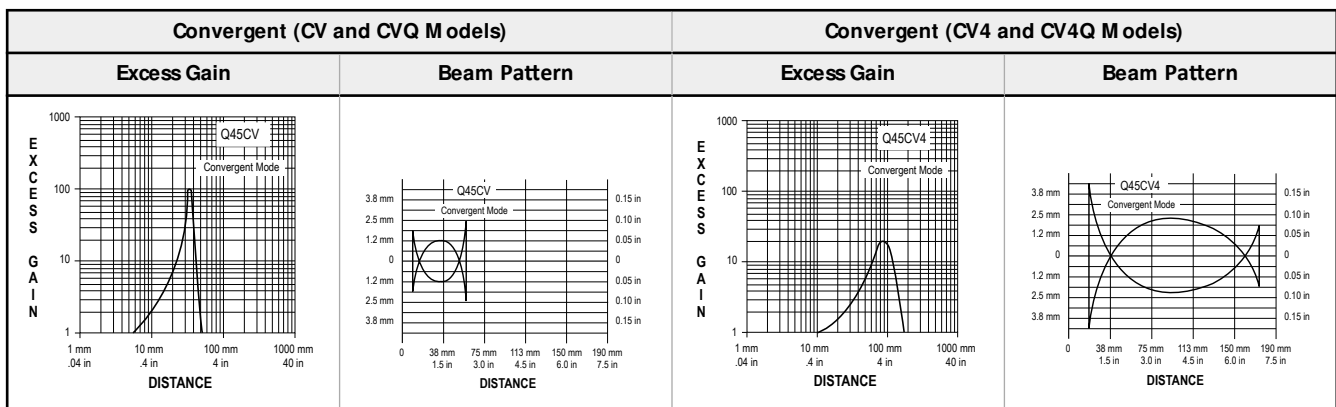

Glass fiber optic Diffuse mode performance curves are based on a 90% reflectance white test card.

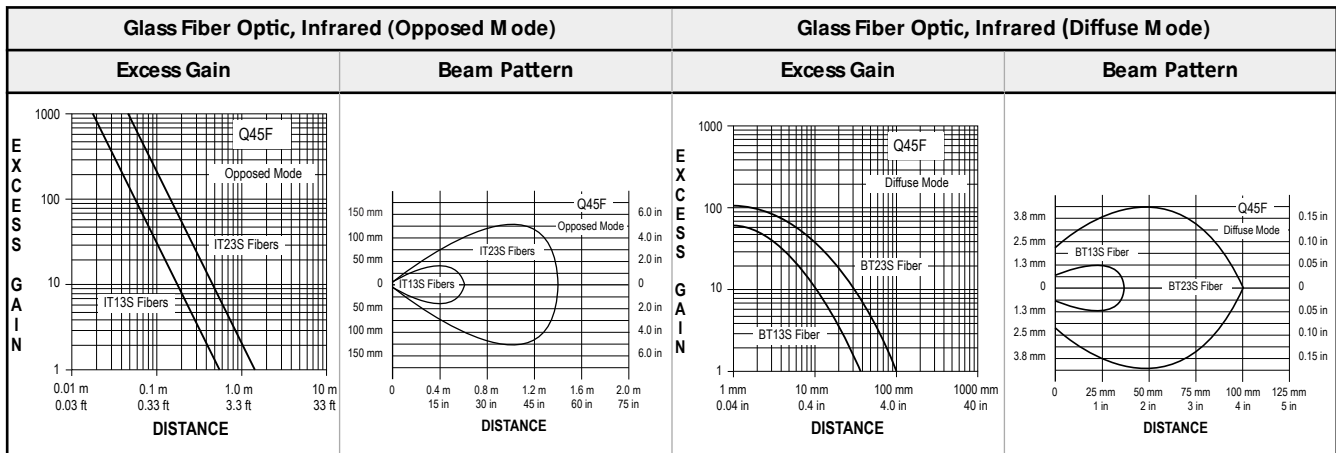

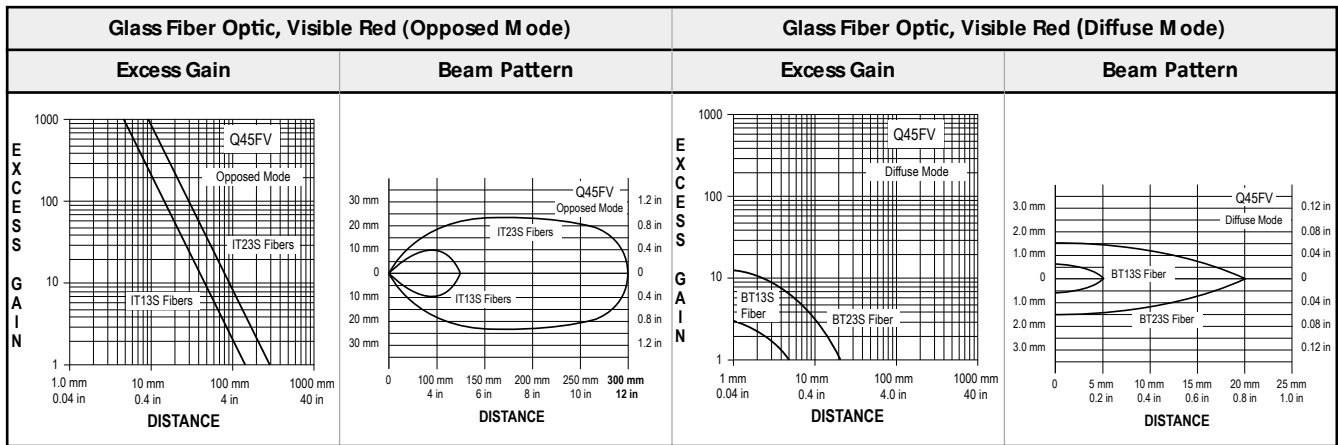

Plastic fiber optic Diffuse mode performance curves are based on a 90% reflectance white test card.

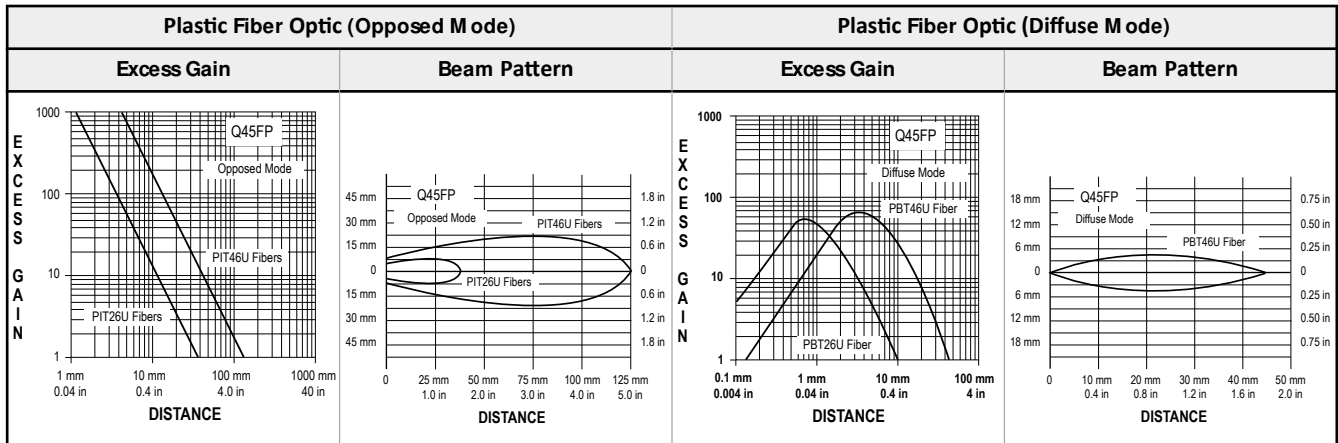

Accessories

Cordsets

3-Pin Mini-Style Cordsets				
Model	Length	Style	Dimensions	Pinout (Female)
M BCC-306	1.83 m (6.5 ft)	Straight		<p>1 = Black 2 = Brown 3 = Blue</p>
M BCC-312	3.66 m (12 ft)			
M BCC-330	9.14 m (30 ft)			

5-Pin Mini-Style Cordsets				
Model	Length	Style	Dimensions	Pinout (Female)
M BCC-506	1.83 m (6 ft)	Straight		<p>1 = Black 2 = Blue 3 = Yellow 4 = Brown 5 = White</p>
M BCC-512	3.66 m (12 ft)			
M BCC-530	9.14 m (30 ft)			

Retroreflective Targets

Banner offers a wide selection of high-quality retroreflective targets. See www.bannerengineering.com for complete information.



Note: Polarized sensors require corner cube type retroreflective targets. Non-polarized sensors may use any retroreflective target.



Brackets

SM B30C

- 30 mm split clamp, black PBT bracket
- Stainless steel mounting hardware included
- Mounting hole for 30 mm sensor

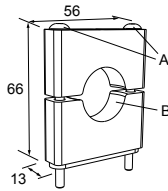

Hole center spacing: A=∅ 45
Hole size: B=∅ 27.2

SM B30M M

- 12-ga. stainless steel bracket with curved mounting slots for versatile orientation
- Clearance for M6 (1/4 in) hardware
- Mounting hole for 30 mm sensor

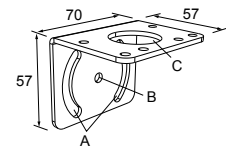

Hole center spacing: A = 51, A to B = 25.4
Hole size: A = 42.6 x 7, B = ∅ 6.4, C = ∅ 30.1

SM B30SC

- Swivel bracket with 30 mm mounting hole for sensor
- Black reinforced thermoplastic polyester
- Stainless steel mounting and swivel locking hardware included

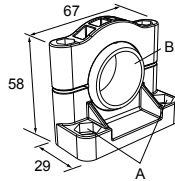

Hole center spacing: A=∅ 50.8
Hole size: A=∅ 7.0, B=∅ 30.0

Output Timing Logic and Signal Strength Display Modules

Q45 sensors easily accept the addition of output timing logic and signal strength display functions. Display modules have a seven-element display that gives a more precise indication of excess gain than does the AID™ system LED that is standard on Q45 sensors. The modules listed below may be used with all Q45VR3 sensors. Refer to the module's datasheet for more information.

Models	Logic and/ or Display Function
45LM58	Programmable output timing logic
45LM58D	Programmable output timing logic plus signal strength display
45LMD	Signal strength display only (no timing function)

Banner Engineering Corp. Limited Warranty

Banner Engineering Corp. warrants its products to be free from defects in material and workmanship for one year following the date of shipment. Banner Engineering Corp. will repair or replace, free of charge, any product of its manufacture which, at the time it is returned to the factory, is found to have been defective during the warranty period. This warranty does not cover damage or liability for misuse, abuse, or the improper application or installation of the Banner product.

THIS LIMITED WARRANTY IS EXCLUSIVE AND IN LIEU OF ALL OTHER WARRANTIES WHETHER EXPRESS OR IMPLIED (INCLUDING, WITHOUT LIMITATION, ANY WARRANTY OF MERCHANTABILITY OR FITNESS FOR A PARTICULAR PURPOSE), AND WHETHER ARISING UNDER COURSE OF PERFORMANCE, COURSE OF DEALING OR TRADE USAGE.

This Warranty is exclusive and limited to repair or, at the discretion of Banner Engineering Corp., replacement. **IN NO EVENT SHALL BANNER ENGINEERING CORP. BE LIABLE TO BUYER OR ANY OTHER PERSON OR ENTITY FOR ANY EXTRA COSTS, EXPENSES, LOSSES, LOSS OF PROFITS, OR ANY INCIDENTAL, CONSEQUENTIAL OR SPECIAL DAMAGES RESULTING FROM ANY PRODUCT DEFECT OR FROM THE USE OR INABILITY TO USE THE PRODUCT, WHETHER ARISING IN CONTRACT OR WARRANTY, STATUTE, TORT, STRICT LIABILITY, NEGLIGENCE, OR OTHERWISE.**

Banner Engineering Corp. reserves the right to change, modify or improve the design of the product without assuming any obligations or liabilities relating to any product previously manufactured by Banner Engineering Corp. Any misuse, abuse, or improper application or installation of this product or use of the product for personal protection applications when the product is identified as not intended for such purposes will void the product warranty. Any modifications to this product without prior express approval by Banner Engineering Corp will void the product warranties. All specifications published in this document are subject to change; Banner reserves the right to modify product specifications or update documentation at any time. Specifications and product information in English supersede that which is provided in any other language. For the most recent version of any documentation, refer to: www.bannerengineering.com.