

Datasheet

Ultrasonic Opposed Mode Sensor Pairs with Dual Sensing Ranges



- Dual range/dual resolution opposed mode ultrasonic sensors; ideal for reliable sensing of clear objects or materials
- Rugged design for use in demanding environments: rated NEMA 6P (IEC IP67), wide-operating temperature range of -40 °C to +70 °C (-40 °F to +158 °F)
- Alignment indicator flashes at a rate proportional to the received signal strength
- Highly immune to ambient sonic and electrical noise
- Popular T-style right-angle sensor package with 18 mm threaded mounting hub; cabled or quick disconnect models
- 12 to 30 V dc operation; choose receivers with either NPN (sinking) or PNP (sourcing) output; outputs are short-circuit protected



WARNING: Not To Be Used for Personnel Protection

Never use this device as a sensing device for personnel protection. Doing so could lead to serious injury or death. This device does not include the self-checking redundant circuitry necessary to allow its use in personnel safety applications. A sensor failure or malfunction can cause either an energized or de-energized sensor output condition.

Models

Model ¹	Range ²	Output	Response Time
T186UE	-	-	-
T18VN6UR	Normal Resolution: 600 mm (24 in)	NPN (sinking)	Normal Resolution: 2 ms
T18VP6UR	High Resolution: 300 mm (12 in)	PNP (sourcing)	High Resolution: 1 ms

Overview

U-GAGE[®] T18U Series Sensor is an opposed mode ultrasonic emitter/receiver pair. It uses an advanced built-in microprocessor to analyze the received ultrasonic signal and control an indicator LED located on the back of the receiver. The receiver LED flashes at a rate proportional to the received sonic signal strength. This indicator greatly simplifies sensor alignment and alerts personnel to marginal sensing conditions because of gradual misalignment or environmental factors. The receiver is precisely tuned to the ultrasonic emitter, making this sensor pair highly immune to both sonic and electrical ambient noise.

T18U receivers may be wired for either of two resolution modes: NORMAL or HIGH. The modes are selected by the polarity of the supply voltage.

- The NORMAL resolution mode offers a sensing range of 600 mm (24 in) and maximizes sensing energy, as is required in demanding environments.
- The HIGH resolution mode yields a sensing range of up to 300 mm (12 in) and maximizes sensing response, as is needed in high-speed counting applications.

Opposed mode ultrasonics are very useful for highly reliable sensing of clear materials, which is always a challenge for photoelectric modes. T18U Series ultrasonic sensors are designed for demanding sensing environments. Housings are tough, NEMA 6P-rated PBT. Electronics are epoxy encapsulated. The acoustic face of both emitter and receiver are epoxy-reinforced for extreme durability and moisture resistance.

¹ The standard 2 m (6.5 ft) cable models are listed. To order a 4-Pin M12/Euro-style integral QD model, add suffix "Q" to the model number (e.g., T18VN6URQ). To order the 9 m (30 ft) cable model, add suffix "W/30" to the model number (e.g., T18VN6URW/30). Models with a QD connector require a mating cable.

² T18U receivers may be wired for either of two resolution modes: Normal or High.



Installation Instructions

Object Detection

These figures reflect the following assumptions:

- Objects have square (not radiused) corners,
- Sensors are optimally aligned,
- Objects pass through the sensing area midway between the emitter and receiver (i.e. at $D/2$),³
- Operating conditions are stable, with minimal air turbulence.

Individual results may differ based on ambient operating conditions, alignment, and the geometry of the objects to be detected.

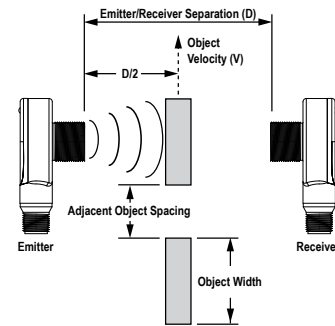

Minimum Object Width (Typical)				
Resolution Mode	Emitter/Receiver Separation (D)	Velocity = 0 mm/ sec (0 in/ sec)	Velocity = 1270 mm/ sec (50 in/ sec)	Velocity = 2540 mm/ sec (100 in/ sec)
Normal	150 mm (6 in)	25.4 mm (1 in)	35.6 mm (1.40 in)	38.1 mm (1.5 in)
	300 mm (12 in)	31.8 mm (1.25 in)	50.8 mm (2 in)	50.8 mm (2 in)
	600 mm (24 in)	25.4 mm (1 in)	44.5 mm (1.75 in)	44.5 mm (1.75 in)
High	150 mm (6 in)	15.2 mm (0.60 in)	19.1 mm (0.75 in)	20.3 mm (0.80 in)
	300 mm (12 in)	12.7 mm (0.50 in)	19.1 mm (0.75 in)	25.4 mm (1 in)

Minimum Adjacent Object Spacing (Typical)				
Resolution Mode	Emitter/Receiver Separation (D)	Velocity = 0 mm/ sec (0 in/ sec)	Velocity = 1270 mm/ sec (50 in/ sec)	Velocity = 2540 mm/ sec (100 in/ sec)
Normal	150 mm (6 in)	0.8 mm (0.03 in)	1 mm (0.04 in)	1.3 mm (0.05 in)
	300 mm (12 in)	2.5 mm (0.1 in)	3.8 mm (0.15 in)	5.1 mm (0.2 in)
	600 mm (24 in)	8.9 mm (0.35 in)	10.2 mm (0.4 in)	12.7 mm (0.5 in)
High	150 mm (6 in)	3.3 mm (0.13 in)	3.8 mm (0.15 in)	4.3 mm (0.17 in)
	300 mm (12 in)	10.2 mm (0.4 in)	11.4 mm (0.45 in)	11.4 mm (0.45 in)

Wiring Diagrams

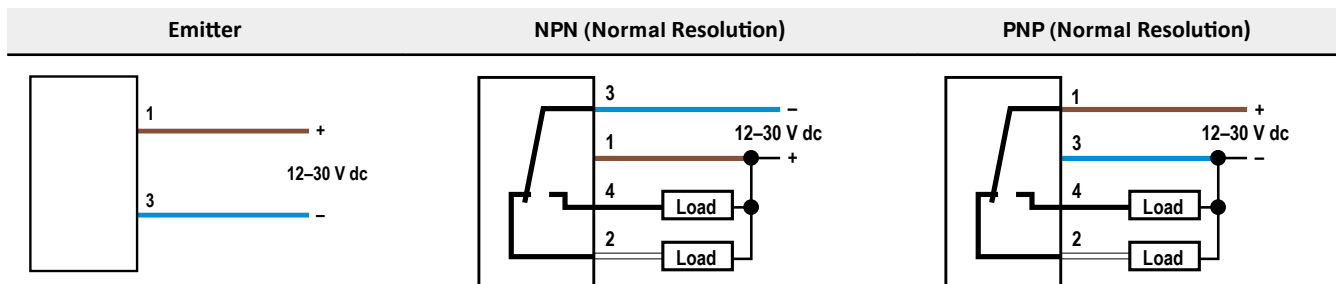

³ In general, the minimum object width and minimum object spacing will decrease if the object (or space) to be detected is passed closer to the emitter or the receiver.

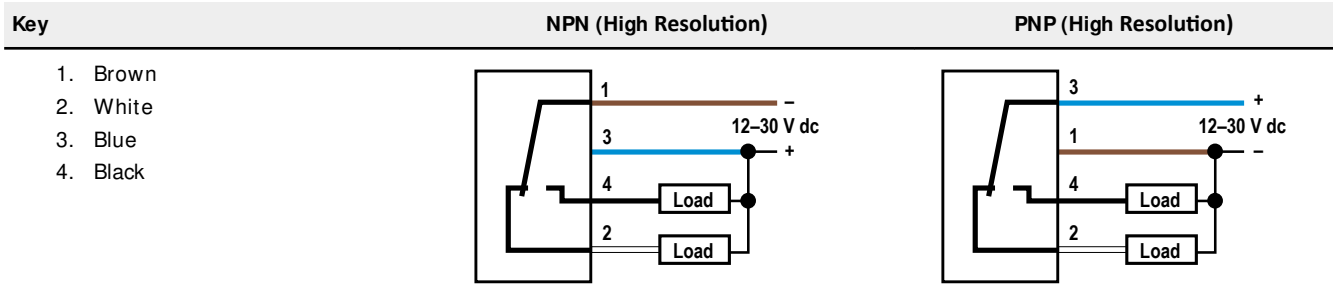

Specification

Supply Voltage

12 to 30 V dc (10% maximum ripple)

Supply Current

Emitters: 50 mA
Receivers: 35 mA, exclusive of output load

Output Protection Circuitry

Protected against overload and short circuit conditions. No false pulse upon receiver power-up.

Delay at Power-up

100 milliseconds

Beam Angle (-3dB full angle)

15 ± 2°

Output Rating

150 mA max. (each output) at 25°C, derated to 100 mA at 70°C (derate ≈ 1 mA per °C). Both outputs may be used simultaneously.
ON-state saturation voltage: < 1.5 V at 10 mA; < 2.0 V at 150 mA
OFF-state leakage current: < 1 microamp at 30 V dc

Rep Rate

Normal Resolution Mode: 125 Hz maximum
High Resolution Mode: 200 Hz maximum

Indicators

Emitters have a Green LED for Power ON.
Receivers have one Green Power LED and one Yellow Signal LED.
Green Power LED: ON indicates power on; Flashing indicates output overload
Yellow Signal LED: sonic signal received (flash rate is proportional to received signal strength; flash is from full to half intensity)

Environmental Rating

NEMA 6P; IEC IP67

Operating Conditions

-40 °C to +70 °C (-40 °F to +158 °F)

Vibration and Mechanical Shock

All models meet Mil Std. 202F requirements. Method 201A (vibration: 10 Hz to 60 Hz max., double amplitude 0.06 inch, maximum acceleration 10G). Also meets IEC 947-5-2 requirements: 30G 11 ms duration, half sine wave. Method 213B conditions H&I.
Shock: 75G with unit operating; 100G for non-operation

Certifications



Sensing Range

Normal Resolution: 600 mm (24 in)
High Resolution: 300 mm (12 in)

Ultrasonic Frequency

230 kHz

Minimum Spacing (adjacent pairs)

50 mm for emitter-to-receiver separations of up to 150 mm
Add 10 mm of adjacent pair spacing for every 100 mm of emitter-to-receiver spacing beyond 150 mm

Receiver Output Configuration

NPN (sinking) or PNP (sourcing), depending on model; Normally Open (NO) and Normally Closed (NC) (complementary)

Output Response Time

Normal Resolution Mode: 2 milliseconds ON and OFF
High Resolution Mode: 1 millisecond ON and OFF

Mechanical Sensing Repeatability at 300 mm (12 in) Range

Normal Resolution Mode: < 2 mm (< 0.08 in)
High Resolution Mode: < 1 mm (< 0.04 in)

Construction

Patented T-style yellow PBT housing with black PBT back cover. Transducer housing is threaded M18 x 1. Mating jam nut is supplied for mounting. Acoustic face is epoxy reinforced. Circuitry is epoxy encapsulated.

Construction

Emitter: 2 m (6.5 ft) attached PVC-covered 2-wire cable or 4-pin Euro-Style quick disconnect fitting
Receiver: 2 m (6.5 ft) attached PVC-covered 4-wire cable or 4-pin Euro-Style quick disconnect fitting
9 m (30 ft) cables available by request.
A model with a QD connector requires a mating cable

Required Overcurrent Protection



WARNING: Electrical connections must be made by qualified personnel in accordance with local and national electrical codes and regulations.

Overcurrent protection is required to be provided by end product application per the supplied table.

Overcurrent protection may be provided with external fusing or via Current Limiting, Class 2 Power Supply.
Supply wiring leads < 24 AWG shall not be spliced.

For additional product support, go to www.bannerengineering.com.

Supply Wiring (AWG)	Required Overcurrent Protection (Amps)
20	5.0
22	3.0
24	2.0
26	1.0
28	0.8
30	0.5

Dimensions

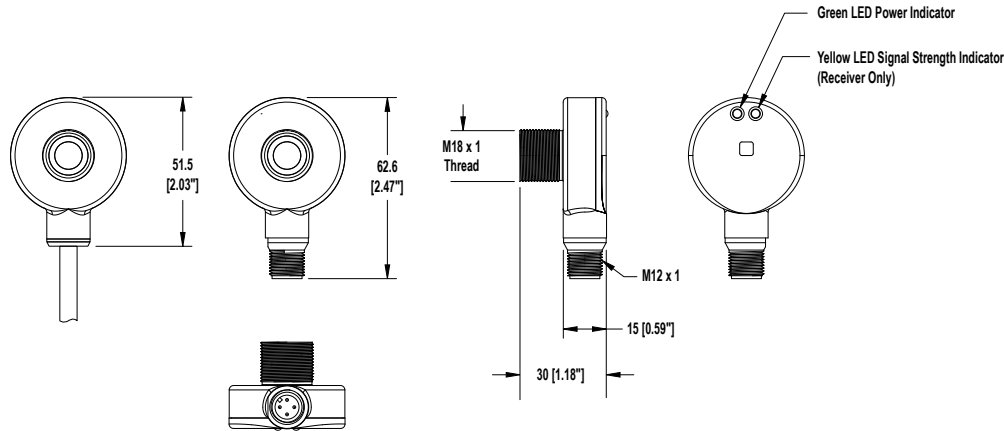

All measurements are listed in millimeters [inches], unless noted otherwise.

Accessories

Cordsets

4-Pin Threaded M 12/ Euro-Style Cordsets				
Model	Length	Style	Dimensions	Pinout (Female)
M QDC-406	1.83 m (6 ft)	Straight		<p>1 = Brown 2 = White 3 = Blue 4 = Black</p>
M QDC-415	4.57 m (15 ft)			
M QDC-430	9.14 m (30 ft)			
M QDC-450	15.2 m (50 ft)			
M QDC-406RA	1.83 m (6 ft)	Right-Angle		
M QDC-415RA	4.57 m (15 ft)			
M QDC-430RA	9.14 m (30 ft)			
M QDC-450RA	15.2 m (50 ft)			

Banner Engineering Corp. Limited Warranty

Banner Engineering Corp. warrants its products to be free from defects in material and workmanship for one year following the date of shipment. Banner Engineering Corp. will repair or replace, free of charge, any product of its manufacture which, at the time it is returned to the factory, is found to have been defective during the warranty period. This warranty does not cover damage or liability for misuse, abuse, or the improper application or installation of the Banner product.

THIS LIMITED WARRANTY IS EXCLUSIVE AND IN LIEU OF ALL OTHER WARRANTIES WHETHER EXPRESS OR IMPLIED (INCLUDING, WITHOUT LIMITATION, ANY WARRANTY OF MERCHANTABILITY OR FITNESS FOR A PARTICULAR PURPOSE), AND WHETHER ARISING UNDER COURSE OF PERFORMANCE, COURSE OF DEALING OR TRADE USAGE.

This Warranty is exclusive and limited to repair or, at the discretion of Banner Engineering Corp., replacement. IN NO EVENT SHALL BANNER ENGINEERING CORP. BE LIABLE TO BUYER OR ANY OTHER PERSON OR ENTITY FOR ANY EXTRA COSTS, EXPENSES, LOSSES, LOSS OF PROFITS, OR ANY INCIDENTAL, CONSEQUENTIAL OR SPECIAL DAMAGES RESULTING FROM ANY PRODUCT DEFECT OR FROM THE USE OR INABILITY TO USE THE PRODUCT, WHETHER ARISING IN CONTRACT OR WARRANTY, STATUTE, TORT, STRICT LIABILITY, NEGLIGENCE, OR OTHERWISE.

Banner Engineering Corp. reserves the right to change, modify or improve the design of the product without assuming any obligations or liabilities relating to any product previously manufactured by Banner Engineering Corp. Any misuse, abuse, or improper application or installation of this product or use of the product for personal protection applications when the product is identified as not intended for such purposes will void the product warranty. Any modifications to this product without prior express approval by Banner Engineering Corp will void the product warranties. All specifications published in this document are subject to change; Banner reserves the right to modify product specifications or update documentation at any time. Specifications and product information in English supersede that which is provided in any other language. For the most recent version of any documentation, refer to:

www.bannerengineering.com.